

Circulating File

RADIONICS/ETHERONICS

**A compilation of Extracts
from the Edgar Cayce Readings**

**Edgar Cayce Readings Copyrighted by
Edgar Cayce Foundation
1971, 1993-2013
All Rights Reserved**

**These readings or parts thereof may not be reproduced
in any form without permission in writing from the
Edgar Cayce Foundation
215 67th Street
Virginia Beach, VA 23451**

Printed in U.S.A.

RADIONICS/ETHERONICS CIRCULATING FILE

Circulating Files are collections of verbatim quotes of what Edgar Cayce said during his readings on a given subject or, in some cases everything. We have medical circulating files which focus on the over 9,000 health-related readings with subjects from Acidity-Alkalinity to Weight Loss. We also have non-medical circulating files on a broad range of topics, for example *Egypt: Sphinx, Pyramids, and Hall of Records*, *Fear and Its Far-Reaching Effects*, *Advice to Parents*, *Serving in Accord with Ideals*, and *Business Advice*.

Each circulating file is simply a collection of reading quotes or full readings given for different individuals on a similar subject or disease. The A.R.E. cannot and does not suggest treatments for physical ailments nor make claims about the effectiveness of the therapies. We encourage anyone working with the health readings to do so under a doctor's care and advice.

The circulating files support the research aspect of the Cayce work. We appreciate any feedback informing us of progress made in improving one's life or achieving good health by applying suggestions given in the readings. Please send any feedback (testimonies, experiences, results, etc.) to:

Library: Circulating File Desk
A.R.E.
215 67th St
Virginia Beach VA 23451 Or e-mail: CirculatingFiles@edgarcayce.org

Please note: The complete Edgar Cayce Readings are available through the members only section of our web site, EdgarCayce.org or on CD-ROM.

Some circulating files contain commentaries or summaries written by physicians. These reports are to be used as a basis for further research in the form of controlled studies, and should not be misinterpreted to be either a refutation or an endorsement by the doctor. Referral doctors wanting to borrow a file for an extended period may do so by writing to the Library: Circulating File Desk.

Our hope is that through the Cayce readings you will find the wholeness and oneness which is God's plan for us.

Blessings, A.R.E. Member Services Team

There are in truth no incurable conditions.... 3744-2

This Circulating File consists of the Edgar Cayce psychic readings on radionics/etheronics. The information is not intended for self-diagnosis nor self-treatment. Please consult a qualified health care professional before following any advice contained within this file.

Articles may be included because the information supports the remedies and therapies described in the Edgar Cayce readings or are of a helpful nature. Their inclusion does not imply endorsement or recommendation. Before following any advice contained in the articles, please seek the counsel of your doctor.

Products may be purchased from Baar Products, the official worldwide supplier of Edgar Cayce health care products: www.baar.com or call 800-269-2502.

**Radionics/Etheronics
Abram's Oscilloclast**

<u>Contents</u>	<u>Pages</u>
A. Introduction to the Edgar Cayce Readings on Health and Healing	5
B. "Radionics" from <i>Edgar Cayce Encyclopedia of Healing</i>	9
C. "A Renaissance of Atlantean Science and Technology"	10
D. General Extracts from the Cayce Readings	15
E. Case Studies from the Readings:	
1. Reading # 440-1, 23-yr-old man (student, electrical engr., life rdg.)	18
2. Reading # 440-3, same man (etheronic machine)	23
3. Reading # 440-6, same man (construction of etheronic machine)	29
4. Reading # 440-11, same man (etheronics, hearing stones sing)	33
5. Reading # 440-12, same man (construction & akashic records)	49
6. Reading # 440-13, same man (construction & usage)	55
7. Reading # 440-15, same man (etheronic/psychonograph machine)	60
8. Reading # 440-16, same man (trip to Arizona & usage)	63
Specifications for Dr. Paul Cold [Etheronic] Machine	69
9. Reading # 442-2, 57-yr-old man (440's father, health rdg.)	79
10. Reading # 443-2, 45-yr-old woman (440's mother, health rdg.)	81
Diagram of Dr. Paul Cold's etheronic instrument	86
11. Reading # 443-3, same woman (life rdg. & questions re machine)	87
12. Reading # 443-4, same woman (health rdg. & machine)	92
13. Reading # 443-5, same woman (theory & construction re machine)	98
14. Reading # 443-6, same woman (use & construction re machine)	104
15. Reading # 490-1, 42-yr-old man (naturopath with psychonograph)	111
16. Reading # 267-2, 38-yr-old woman (health rdg. requested by 440)	116
17. Reading # 294-167, 56-yr-old man (Edgar Cayce, cough)	121
18. Reading # 967-1, 42-yr-old woman (healing interests)	122
19. Reading # 1397-1, 58-yr-old woman (healing interests)	123
20. Reading # 1436-3, 27-yr-old woman (healing interests)	126
21. Reading # 1504-1, 48-yr-old woman (polio)	129
22. Reading # 1553-11, 71-yr-old woman (dementia)	133
23. Reading # 1997-3, 60-yr-old woman (insomnia, hypertension)	136

RADIONICS/ETHERONICS CIRCULATING FILE

More on Abram's Oscilloclast*

Diagrams & information: Turn of the Century Electrotherapy Museum* 139

24. Reading # Reading # 3875-1, 3-yr-old boy (abnormal)* 140

25. Reading # Reading # 5138-1, 51-yr-old woman (health reading)* 144

F. Articles:

1. "Beach Chiropractor Prescribes Colors, Psychic Vibrations", 10/18/7 74

2. "Aetheronics", 2/24/47 125

3. "The Eminent Medic – Turned – Quack", 1/13/70 143

4. "Legacy of A Quack", 1/14/70 144

5. "Controversy Over Weird Healing Gadget", 10/6/51 148

6. "School Board Head Backed "Ray" Claim", 10/13/51 149

7. "Hospital Heat Machines Are Confiscated by FDA", 7/3/72 152

G. Related Circulating Files and Research Bulletins* :

1. Appliances: Radio-Active Appliance

2. Appliances: Wet Cell Battery

3. Perpetual Motion Machine

H. Interview with Sidney Kirkpatrick at the A.R.E., Etheric machine displayed:

http://www.youtube.com/watch?feature=player_embedded&v=fFD7Z0AVyNk

440-3, 23-yr-old man, electrical engineer, student

(Q) Is Dr. Cold's instrument, designed for [440] of real medical value? a diagram of which I hold in my hand?

(A) This is rather approached from the wrong angle! It isn't of a MEDICAL value so much as of an ATOMICAL value to the vibrations of the body!...

(Q) What is the best substance for induction, conduction, transmission of etheronic energy?

(A) This is as raised power that would be produced from a combination of crystals. This should be rather interesting to this body, for it is very much like that used by the body in the Atlantean sojourn! Not that which caused the cosmic ray, or the death ray, or the healing ray - but the ray that came from setting of the prismatic influences from high heating - it may be from Arcturus or it may be from the Sun; though Arcturus would be nearer proper.

The Sun may be induced to make for destructive or constructive forces, either one. It's a combination of those forces or rays that may be gathered in certain setting of prisms. It would require a lot of detail in preparing same.

We would rather refer this to a later period, or seek other channels that may aid with the combination of these.

* Circulating Files & Research Bulletins are available from A.R.E. membership services at (800) 333-4499 or: <http://www.edgar cayce.org/circulating>

Introduction to the Cayce Readings on Health and Healing

No matter what illness or ailment concerns us, certain basic principles about health and healing are relevant. These are the premises upon which all of the Cayce health information rests. For those who would like to make a more careful study of these basic principles, the recommended Circulating File is entitled *Principles of Healing*. Here, in essence, are the ideas found in that file. They may prove to be very useful to your study of the specific ailment that requires healing for you.

The first fundamental idea about healing requires that we maintain a creative balance between two principles:

1. All healing comes from the infinite - that is, from attunement and harmony with our spiritual source. The infinite is just as accessible and available in the visible, physical world as it is in the invisible realm.
2. At the same time, each person must take responsibility for his or her own healing process. No one can simply sit back and wait passively for healing to occur.

This second principle - the need for self-responsibility - can take many forms. For example, healing requires attunement, and no one knows better than ourselves exactly what has gotten us out of attunement. Often, if we look closely at our lives, we can see (without needing a gifted medical clairvoyant such as Edgar Cayce) what's causing our illness.

To illustrate self-responsibility further, the human body has a marvelous, innate drive to heal itself, but we've got to do our part to help. A broken bone will naturally try to mend; however, the fracture needs to be set properly for the healing to be complete and effective. Cayce stresses the healing ability of the body:

Remember, the body does gradually renew itself constantly. Do not look upon the conditions which have existed as not being able to be eradicated from the system. . . Hold to that KNOWLEDGE - and don't think of it as just theory - that the body CAN, the body DOES renew itself! 1548-3

Another important principle relates to energy medicine, a new field for which Edgar Cayce was a pioneer. His readings consistently speak of the roles played by vibrations or vibratory forces - right down to the level of individual atoms. According to Cayce, there is a type of consciousness that exists in each atom. Although most of the passages about the atomic physics of healing seem rather esoteric, it might be easier to follow the analogy of the attunement of a stringed musical instrument. A violin or piano that is out of tune makes sour, discordant music - symbolic of disease or illness. Just as a skilled musician can bring the instrument back into attunement, we experience healing when our vibrations - right down to the atomic level - are adjusted in a correct manner. In essence, all healing is bringing the vibrations into harmony from within.

Balance among body, mind, and spirit is another key to Cayce's philosophy of healing. For healing to be complete and lasting, we must recognize and meet the needs of each of these three levels. Virtually no illness or disease can be treated successfully at only one of these three levels.

RADIONICS/ETHERONICS CIRCULATING FILE

What's more, Cayce affirms that the human body will naturally stay healthy - and even rejuvenate itself - if a kind of internal balance can be maintained. "Dis-ease" starts when one part of the body draws energy from another part. One portion of an organism may become overcharged with the creative life force, while another portion becomes undernourished. The result is a gradual disintegration of the body and the onset of illness.

The opposite of this sort of disintegration is rejuvenation. The readings assert that we are continuously rebuilding our bodies. Within any seven-year period, each cell is replaced. If we'll allow it, our bodies will transform any problem and resuscitate any condition. But our ingrained habits usually block this healing potential - the habits of action and, even more potent, the habits of mind.

What role do drugs and medicine play in the healing process? Cayce's philosophy clearly sees a place for them, but warns of misunderstanding how they work and of expecting more of them than is possible. Any healing method attempts to create an experience of oneness, in hopes of then stimulating a similar response in the body. For some people in some situations, a drug may be the best way to accomplish this - just as in other cases surgery may be the best way to stimulate healing. Medicines can be a practical application of the one life force. Occasionally they must be very potent in their reactions in order to get the patient through an acute illness. But Cayce from time to time encouraged people to consider the herbal formulas he recommended to be tonics and stimulants, rather than medicines.

The dangerous side of medicines is their potential to diminish the body's own healing work. This is what Cayce alluded to when he warned about "palliatives" that deceive the soul with half-truths and temporary relief. It's also what he meant when he warned that we shouldn't come to rely on any condition outside of ourselves that could be assimilated by the body inwardly. All of this is to say, take the medications prescribed by the physician you trust. Keep in mind this thought: what those chemicals can do is temporarily - and somewhat artificially - give your body an experience of greater oneness.

Healing that really takes hold and lasts must come from changing one's inner consciousness and vibration. That happens most effectively from consistent and persistent human effort (that is, engaging one's desires, purposes, and will) - something that pills all too easily allow us to skip.

These have been long-standing. Do not take the treatments just a few days, or even a few weeks, and expect to be well - and then revert to old conditions. But be consistent and persistent! Have periods when these will be taken (that is, ALL of those things indicated) for two, three to four weeks. Then rest by leaving them off a week. And then be just as patient and just as persistent as though you were beginning all over again. 976-1

Cayce's healing philosophy includes other insights that can help us avoid misunderstanding. For example, one principle states that the best treatment procedures sometimes cause a temporary worsening of conditions. If we didn't recognize this possibility, we might give up just before the benefits begin to appear. A closely related principle states that when a body is re-establishing its attunement, it tends to be more sensitive. Again, if we misunderstand that heightened sensitivity, we might not see the good that is slowly being effected.

The mind is a focus of other healing principles. The unconscious mind plays a role in many illnesses and diseases. One example of this is the karmic factor in health problems. Memories from previous incarnations, stored in the soul mind, can trigger problems in the body. Of course, we shouldn't go so far as to suppose that every health challenge has past-life roots; nevertheless, the perspective of reincarnation can help us understand what we could possibly be dealing with as we seek healing.

The familiar Cayce axiom, "Mind is the builder," leads us to wonder exactly which attitudes and emotions best foster healing. The readings emphasize several:

- Self-acceptance. As we rid ourselves of self-condemnation, we make room for healing forces to enter.
- Optimism and hope. We're encouraged to expect healing.
- Patience. It's much easier and quicker to destroy health than it is to rebuild it. We need to be willing to patiently invest whatever time is required.

Alongside these specific attitudes and emotions, we're invited to use the creative potential of visualization to stimulate our own healing. The mind's image-making capacity can be directed in such a way that we "see" the healing transformation taking place. This is not something that's accomplished in a single visualization session. Like all the Cayce health-promoting approaches, it requires persistence and works best in conjunction with other healing methods.

Perhaps the most important principle of the mind's relationship to healing concerns purposefulness. A person can experience temporarily an outer healing - that is, in the physical body only - yet still be spiritually sick. What cures the soul? A commitment to a purposeful life. Not just any purpose, but instead one that reflects care for other people.

On occasion a reading from Cayce would pose this question to the person who was ill: What would you do with your life if you were healed?

What would the body be healed for? That it might gratify its own physical appetites? That it might add to its own selfishness? Then (if so) it had better remain as it is. . . But first the change of heart, the change of mind, the change of purpose, the change of intent. 3124-2

The position of Cayce's psychic source was simply this: Why correct the physical condition unless there's also going to be an inner correction? People who are looking for both inner and outer healing are the best candidates for restored health and vitality. In Cayce's philosophy, healing should equip us to be more useful to others.

With this ideal of service in mind, we might also wonder just how we can be channels of healing to others. What principles govern our efforts to be healers to those for whom we have concern? One principle is based on the spiritual connections that exist between all people. It states that as we bring the experience of oneness into our own consciousness, it can profoundly help someone else experience oneness, attunement, and healing. Cayce's way of putting it was, "...raising the Christ Consciousness in self to such an extent as it may flow out of self to him thou would direct it to." (281-7)

For this to be most effective, the recipient must desire such help and have requested healing prayer. Of course, we can always pray for someone, even if that

RADIONICS/ETHERONICS CIRCULATING FILE

individual hasn't asked us. But it's important that we not assume we know what's needed in any person's life. For one who hasn't specifically asked for prayer, we can simply offer prayers of protection and blessing, rather than try to direct healing energies to that person or for a specific condition.

It is also important to remember that each reading was given for an individual. It must be emphasized that no suggested treatments for any particular ailments should be "lifted" from any individual reading and tried by another individual except under the supervision of and with the cooperation of a physician or licensed health care professional. However, there were many suggestions that were given over and over, and these can be studied to find how they apply to ourselves. These healing principles can be grouped in four categories that referred to as CARE.

Circulation – moving the blood around the body through therapies such as massage or spinal manipulation

Assimilation – encouraging the body to pull the proper nutrients from the food by eating the proper foods and in the proper combinations

Relaxation – taking time to rest and let the body recuperate and counterbalance the daily activities

Elimination – removing the waste products from the body through therapies such as sweats, colonics, and fume baths

For more information about CARE and recommendations on the lifestyle described in the readings, please see Dr. Harold J. Reilly's *Handbook for Health*. There are also many verbatim collections of the readings in other Circulating Files, Research Bulletins, and Treatment Plans for individual diseases which may be purchased through Customer Service at 800-333-4499.

The A.R.E. is interested in having all the material in the health readings reviewed by physicians and health care professionals who also provide summaries of their findings in the hope that the information may prove beneficial to others. When time and finances permit it is planned to have all the information in the health readings read by one or more physicians and the subject matter summarized. Please send any feedback to

Library: Circulating File Desk

A.R.E.

215 67th St

Virginia Beach VA 23451 Or e-mail: CirculatingFiles@edgarcayce.org

To obtain health items mentioned in the readings, contact our official worldwide distributor, Baar Products at 800-269-2502 or Baar.com.

We do not advocate a do-it-yourself process. Please seek out the advice of a health professional before implementing any recommendation.

In summary, the Cayce readings remind us that our natural state is wholeness and health. An innate wisdom within ourselves knows what's needed for healing. We should expect to get well, and we should be willing to do our part to make it possible. "Those that expect little of the Lord receive little; those that expect much receive much - if they live it!" 1424-1

Blessings,

A.R.E. Member Services Team

Radionics

Reba Ann Karp

Edgar Cayce Encyclopedia of Healing

Radionics was mentioned in over forty readings and referred to a controversial diagnosis and treatment method involving devices known in Edgar Cayce's day as the Oscilloclast, the Abrams Machine, and (Cold's) etheronics. Its developer, the medical doctor Albert Abrams of San Francisco, devoted many years of research toward the scientific establishment of an "electromagnetic" basis for health and disease.

Abrams' device, popularly known as "The Black Box," could allegedly diagnose illness by contact with the patient or by a simple drop of the patient's blood. It could heal, even over distances, by broadcasting pulses of a type of radionic energy tuned to alleviate the particular disorder.

Abrams' electromagnetic theory closely paralleled Cayce's view of life as vibrational or electrical in nature. He frequently noted that "life is, and its manifestations in matter are of an *electronic* energy" (440-16). Cayce suggested radionics both for research and development and as an aid to physical health, especially in cases involving nervous incoordination.

440-13, M 23 (electrical engineer, student), 1/19/34

(Q) Explain more in detail the settlement "Etheronic energy IS mental control." [See 443-5, Par. 18-A on 1/9/34.]

(A) A thesis of 184 pages may be written, my son, on this. But etheronic energy is the emanation from the spirit force through the active force of that which makes for matter being held in its positive position, or in its space of activity. Hence thought as of a body, whether of an animal or a plant, is shown as of plant receiving in its freshness of vigor influences that come from or through the etheronic energy in its activity upon the body, in the expression or upon the plant as in its expression. Hence things that are equal to the same thing are equal to each other....

(Q) Is there any other advice or guidance for this body?

(A) As indicated for the body, and for those that have through the giving of themselves in thought and in activity to creating an influence in the experience of others that may mean so much in their expression of their portion of life, remember these carry with them their responsibilities also. Keep self, then, in accord with that thou knowest to be in accord and in the realm of that best within thine self, that thou wouldst have expressed in thine brother. For, as given, "As ye sow, so shall ye reap." For these influences, these forces that are lent to thine own understanding must be returned with those as thine Lord, thine God, would require of thee. For to whom much has been given much is required. Be ye faithful to that thou knowest.

A Renaissance of Atlantean Science and Technology

If we are witnessing a reincarnation/ renaissance of Atlantean influence predicted by Edgar Cayce, perhaps our present-day advances in the use of medical and industrial lasers, Star Wars "death ray" for destroying enemy rockets in flight, and our fascination with anti-gravity craft are merely reflections of that extinct civilization.

By David McMillin

Without doubt the Cayce readings on Atlantean technology are extremely attractive to individuals mesmerized by the staggering advances in modern theoretical physics – breakthroughs that make it increasingly difficult to distinguish between science and science fiction (more on this later).

During the decade of the 1920s, Edgar Cayce gave many readings for businessmen and entrepreneurs with a keen interest in innovative science and technology with a distinctive Atlantean flavor. The special series of readings on Atlantis, and life readings that discuss this advanced civilization, provide additional details on highly-developed science and technology that resonate strongly with our materialistic, high-tech culture.

Apparently the Atlanteans made use of various exotic energy applications, including crystal technology and flying machines, that utilized the mysterious "nightside" forces of nature.

One of the key individuals who sought Cayce's advice during the 1920s was an Ohio businessman and entrepreneur named Tim Brown. Brown was a member of the Association of National Investigators, Inc., the organization for exploring Cayce's psychic abilities prior to the founding of the A.R.E. He had been helped with a hearing problem by a simple device consisting of two pieces of steel (immersed in cold water) with connecting wires and disks that were attached to the body. Brown recognized the commercial potential of this type of appliance and sought a series of readings on how to manufacture and distribute it as a commercial product. It was called the "radio-active" appliance and is still available as a commercial product (www.baar.com or call 610-873-4591). Despite its worrisome name (which has been changed numerous times over the years), the "radio-active" appliance does not involve toxic nuclear energy associated with modern power plants and weapons. Rather, the device utilizes subtle, "vibratory" energies resembling radio waves that emanate from the body.

One reading called it a "radionics" device. Radionics is a field of subtle energy technology that originated from the research of Albert Abrams, M.D., during the late 19th century. It is a method of diagnosis and treatment at a distance, based on the energy patterns of the afflicted individual. Several Cayce readings discussed and explicitly endorsed the "radionic" and "etheronic" technologies that were developed in that era.

The Perpetual Motion Motor

In addition to energy medicine devices, Brown also became involved in research and experimentation with a "perpetual motion motor," an invention intended to provide a source of efficient, virtually unlimited energy. Numerous readings were given on the theoretical and technical aspects of the device that provide a fascinating

A Renaissance of Atlantean Science and Technology

glimpse into the workings of the universal forces. The readings given to improve the design of the motor insisted that the device could be scaled up to produce almost any level of energy output desired.

In addition to the commercial and technical challenges of developing this device, Brown sought to understand the theoretical basis



David McMillin, M.A., is a researcher and author, having written 11 books and numerous articles on Edgar Cayce's approach to health and healing. Of particular relevance to this article, The Radial Appliance and Wet Cell Battery (co-authored with Douglas G. Richards, Ph.D.) is a scholarly exploration of two of Edgar Cayce's most frequently prescribed energy medicine devices. Visit www.mcmillinmedia.com for more information about David's work.

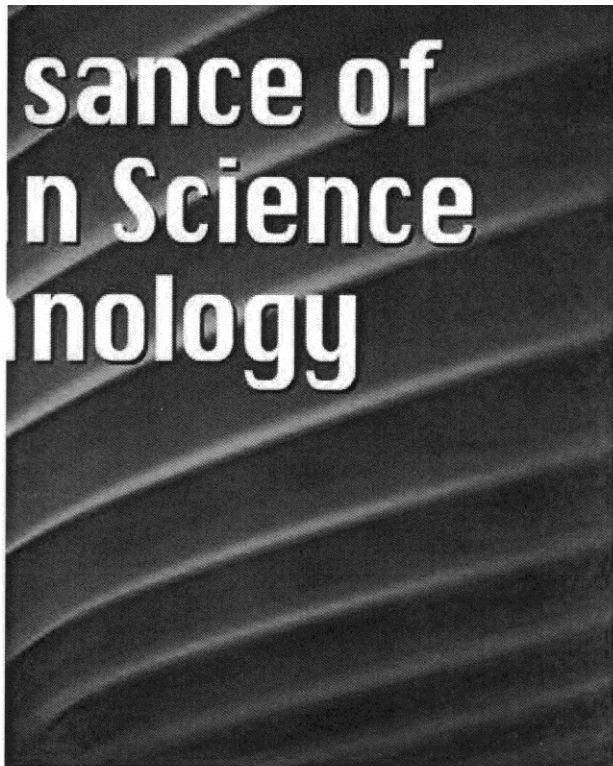

for the universal forces from which it derived its energy. Keep in mind that during this era Einstein's theories of relativity had created quite a stir, rippling well beyond the scientific establishment. Thus Brown was interested in the concepts of "relativity of force" and "unity of force" that had fascinated Einstein's cosmic mind.

The genesis of quantum physics was also in the intellectual wind, with all of its mystical overtones involving elemental forces at the atomic level. Brown and his associates in the Association of National Investigators, Inc. studied the contemporary scientific literature and sought Cayce's views on the important movements in human thought that were being advanced at that time.

The Law of Relativity of Force

In 1929 Brown sought a reading (195-54) to better understand the "law of relativity of force" as applied to the perpetual motion motor that his team of investigators was developing. Edgar Cayce began his dissertation by acknowledging that the technical language for explaining such concepts of

alchemical expression ("nightside" forces) to describe how the opposite aspect of gravity (i.e., negative gravity) could be harnessed in such a motor.

Traditionally, gravity is regarded as a relatively weak attractive force whereby the mass of one body attracts that of another. The readings acknowledged this straightforward property of gravity, but went further to explain other mystifying aspects of gravitational forces that could be used with mechanical devices.

When asked by Brown if

"vibratory force" was inadequate and thus "there will be the necessity of coining other words, as it were, to express just what is meant; for one may say 'relativity of force' and it covers a multitude of sins, ideas, or of actual force in action! One may say gravity - and who understands just what is meant?"

To be sure, physicists are still struggling to understand gravity and are constantly coining new terms as they grapple with understanding the primary forces of nature. In this reading Cayce

resorted to an alchemical expression ("nightside" forces) to describe how the opposite aspect of gravity (i.e., negative gravity) could be harnessed in such a motor. Traditionally, gravity is regarded as a relatively weak attractive force whereby the mass of one body attracts that of another. The readings acknowledged this straightforward property of gravity, but went further to explain other mystifying aspects of gravitational forces that could be used with mechanical devices. When asked by Brown if "vibratory force" was inadequate and thus "there will be the necessity of coining other words, as it were, to express just what is meant; for one may say 'relativity of force' and it covers a multitude of sins, ideas, or of actual force in action! One may say gravity - and who understands just what is meant?" To be sure, physicists are still struggling to understand gravity and are constantly coining new terms as they grapple with understanding the primary forces of nature. In this reading Cayce

resorted to an alchemical expression ("nightside" forces) to describe how the opposite aspect of gravity (i.e., negative gravity) could be harnessed in such a motor. Traditionally, gravity is regarded as a relatively weak attractive force whereby the mass of one body attracts that of another. The readings acknowledged this straightforward property of gravity, but went further to explain other mystifying aspects of gravitational forces that could be used with mechanical devices. When asked by Brown if "vibratory force" was inadequate and thus "there will be the necessity of coining other words, as it were, to express just what is meant; for one may say 'relativity of force' and it covers a multitude of sins, ideas, or of actual force in action! One may say gravity - and who understands just what is meant?" To be sure, physicists are still struggling to understand gravity and are constantly coining new terms as they grapple with understanding the primary forces of nature. In this reading Cayce

The Dark Universe and Cosmic Ether

The latest findings of astrophysics suggest that the universe has a dark side. This startling realization, acknowledged by many leading astronomers, is that at least 90 percent of the universe is invisible. The missing com-



Much Atlantean technology was based on the use of crystals to capture and transmit cosmic energies. This power station has a domed roof that could be retracted to allow light from the sun and stars to enter. At the center of the building was an enormous crystal ("Tuaoi stone") that converted the energy into a form that was broadcast to vehicles on land, in the air, and underwater.

ponents of the universe have been labeled "dark matter" and "dark energy." In this case, "dark" simply refers to the absence of light, rather than anything of an ethical or moral nature.

Since *dark matter* does not radiate energy, it is undetectable by the ordi-

nary tools of astronomical observation. Although scientists cannot see it, many believe that it exists because they can observe its gravitational effect of *attraction* that influences large heavenly entities such as stars and galaxies.

Despite its confusingly similar name, *dark energy* is a different phenomenon that can only be measured indirectly by its peculiar gravitational effect that creates a mutual *repulsion* (i.e., "negative gravity") between objects normally attracted to each other by gravity. Does this sound familiar? It should, because it is precisely the effect that Edgar Cayce described to Tim Brown over 75 years ago in reading 195-54 as the basis for the perpetual motion motor!

Furthermore, the idea of a mostly-dark universe bears a striking resemblance to a very old idea called "ether." Until a little over a century ago, many physicists were convinced that the universe was permeated by an extremely fine substance called ether (derived from the Greek meaning "upper air"). Transparent, incompressible, and continuous, ether was thought to be a medium for the propagation of light, much in the same way that sound is carried through liquid, gas, and solid

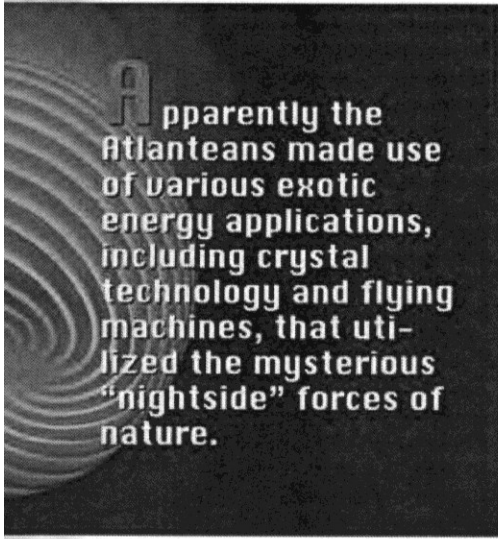

Apparently the Atlanteans made use of various exotic energy applications, including crystal technology and flying machines, that utilized the mysterious "nightside" forces of nature.

matter. With the invention of the radio, the ether was postulated as the medium for the transference of electromagnetic phenomena. An investigation conducted in 1881 (the Michelson-Morley experiment) was accepted by the scientific establishment as disproving the ether theory, as it was conceptualized at that time. The recognition of an invisible substance and energy that permeates and interpenetrates the entire universe has resurrected the specter of an ether-like model that can be used to explain both natural and paranormal phenomena.

The Nightside Forces

One of the fascinating parallels of dark matter and dark energy in the Cayce readings is the concept of "nightside" forces. As with dark matter and dark energy, the use of the word "night" in this context conveys invisibility (in contrast to the visibility of

daylight). Thus *nightside* also implies a dualistic quality of opposition that we find in electromagnetism (i.e., positive and negative electrical charges) or the opposing forces of positive and negative gravity.

According to the readings, the nightside forces are the basis of occult and alchemical processes that can easily become destructive. Several readings discuss an advanced technological culture in prehistoric Atlantis that utilized the power of the nightside forces for transportation, communication, and construction. The nightside forces were initially used for positive purposes. Misapplication of the nightside forces eventually led to catastrophes that destroyed the civilization. Perhaps the ancient Atlanteans were able to detect and harness the power of dark matter and dark energy. If so, the recent discovery of these universal factors could be just the latest echo of the Atlantean influence that has been ringing in our collective consciousness for the past several decades.

For example, a 25-year-old woman seeking a life reading from Edgar Cayce was given this information: "In the one before this we find in that period when known as Alta, in Atlantis. The

entity among those who were of the highest development in the material application of these forces as pertain to the *nightside* of life, or the ability to apply that of forces not at present [1928] used in many ways for man's own use. The entity may gain in material sense through the application of self to inventions, or those things that have to do with power, or through electrical or *wind* application." (2913-2) Similarly, Cayce told numerous individuals that they could use inner attunement to re-

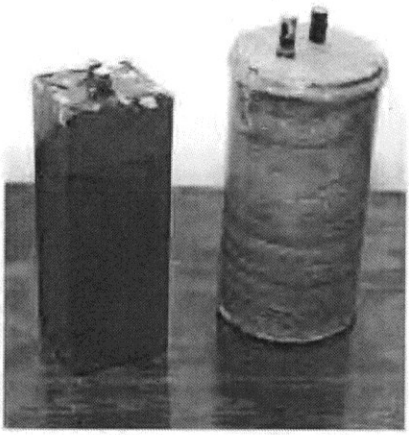

Above: Homemade radionics, or "radio-active," devices made by Marsden Godfrey in the early 1940s. Center: Original etheronics machine made and donated to the Edgar Cayce Foundation by readings recipient Thomas Mitchell Hastings, Jr., in the 1930s. Far right: A Wet Cell appliance made in the 1960s by W.H. Harper, Jr. of Phoenix, AZ.

call scientific and technical information from past lives if they made that choice – yet they should be clear that the intent was for service to others rather than purely self-interest.

Subtle Energies

The prospect that we are living in a universe consisting primarily of undetectable matter and energy raises some interesting possibilities with regard to the concept of subtle energies described in various mystical traditions, including the Cayce readings. The most obvious is the use of the term "etheric" (as in etheric plane of consciousness, etheric body, etc).

The readings made many references to the ether, the etheric body, and the etheric plane. Cayce gave numerous psychic dissertations on "etheronic" technology such as the etheronic ma-

chine developed by Dr. Paul Cold for diagnosing and treating illness. The akashic records from which Cayce obtained information for some of his readings were said to be recorded on the universal ether.

In addition to the etheric realm, the readings also discussed other subtle



energy bodies that operate on unseen planes (e.g., astral, cosmic, celestial, mental, spiritual, etc.). The implication is that each soul is a multidimensional entity with subtle energy bodies suitable for functioning in a multidimensional universe.

String Theory

The multidimensional model of reality has received a boost from an exciting new development in theoretical physics called "string theory." String theory enthusiasts have dubbed this adventurous hypothesis the "theory of everything." In essence, string theory is a highly technical approach to solving the deep mysteries of physics by combining complex mathematical formulas with the rather simple idea that

extremely small vibrating strings are the basis for the physical universe.

Prior to the emergence of string theory, modern physics had been intently focused on the pursuit of smaller and smaller particles by smashing atoms without any good model for understanding what makes up subatomic units. The amazing answer may be tiny vibrating strings!

Interestingly, string theory bears



some striking similarities to the Cayce perspective on how the universe works. Of particular note is the emphasis on unity, vibration, and multidimensional reality.

Unity of Force

One of the strongest themes throughout all the Cayce readings is that of unity. All force is one force (or in the religious parlance of the readings – the "Lord thy God is One"). The one force that created and maintains the universe is the same as the life force that flows through the centers in the human body. The readings assert that "the force in nature that is called electricity is that same force ye worship as Creative or God in action." (1299-1) The very essence of life itself is the Creative Force, or God, manifesting as a low electrical vibration.

In recent decades the holy grail of physics has been the pursuit of a "unified field theory" that combines the power and precision of the quantum mechanics of the subatomic realm with the cosmic scale of Einstein's theories of relativity. Thus the goal is to understand how the primary forces of nature are all just different manifestations of the same one force. String theory (in its latest version called "superstring theory") has been touted as achieving this elusive unification of force.

Vibration

As noted, string theory is based on the premise of extremely small vibrating strings that are the basis for all manifestations of energy and matter. Theoretically, the frequency and resonance at which the strings vibrate result in all the variations of matter that we find all about us ranging from apples and oranges to vast, swirling galaxies. It's all the same stuff vibrating at different rates – a virtual music of the spheres.

That is exactly the way Edgar Cayce described the nature of physical reality. At a practical level, Cayce explained health and illness within the human body as a matter of vibratory rates. Each organ of the body vibrates at its own specific frequency. Too much or too little energy can result in vibratory

imbalances. Various vibrational energy medicine therapies prescribed in the readings are intended to work with the vibratory energies of the body.

String theory provides a conceptual model for understanding how vibration is the basis for understanding how the human body and the universe in its totality are created and maintained. It is easy to see why enthusiasts for this approach call it a "theory of everything."

Multidimensional Reality

The third remarkable similarity between Cayce's cosmology and string theory is the concept of multidimensional reality. To be sure, standard physics recognizes multiple dimensions (three dimensions in space plus time).

However, string theory posits at least 10 or 11 dimensions. The extra six or

seven dimensions are beyond our normal perceptual range, but are essential for the elaborate mathematical formulas that are the foundation of this model.

Edgar Cayce used a similar multidimensional model to explain the workings of the universe. Cayce insisted that our own local solar system operates in eight dimensions. Just like string theory, the extra dimensions are invisible to our earthly-oriented senses. However, the Cayce readings suggest that each soul has the inherent capacity to operate in the extra dimensions that correspond to the planets in this system. Apparently, between earthly lives, souls exist on the other planets (planetary or astrological sojourns) via multidimensional subtle energy bodies. Astronauts visiting other planets in our solar system will not be able to detect these sojourning souls unless they are equipped with subtle energy sensing devices (or are extremely psychic!).

Cayce's recognition that we are multidimensional entities living in a multidimensional universe, that "everything is vibratory," that gravity can best be understood as "octaves" of vibration, and that there are gravitational influences (i.e., "nightside" forces) that can both attract and repel – all of this and much more in the readings is consonant with the latest scientific theories. Considering the comprehensiveness and unity of the Cayce material, it represents more than the "unified field theory" pursued by scientists. It truly qualifies as a unified theory of knowledge, a body of information that comes closest to a "theory of everything" that is presently available to humanity. Yet for Edgar Cayce, theory is never enough – in the application comes the awareness of universal forces.

Looking Ahead

Currently there appears to be a renewed interest in Cayce's ideas on alternative energy applications amongst A.R.E. members with a consciousness like that of Tim Brown and his associates in the Association of National Investigators, Inc. As we have seen, when the conceptual framework in the readings is placed side-by-side with the latest in theoretical physics, the readings actually measure up rather well. With the arrival and maturation of more Atlantean-minded souls and the deepening energy and pollution

crises that we are facing, we can expect to see an increased reliance on science and technology to address these challenges. Will the perpetual motion motor power the houses and vehicles of our grandchildren?

We might also anticipate advances in related technologies such as the aurascope (for viewing the body's subtle energy field), devices for reading the akashic records and communicating with the dead – all of which were predicted in the readings. Use of medical devices based on the principles of radionics and etheronics may also become more widely accepted.

As we look ahead, it would be well to consider the "First do no harm" principle. Working with universal energies is not inherently benign. Advanced technology has contributed to some of the problems that we are now facing. Advanced technology had a destructive influence in Atlantis. Focusing on a spiritual ideal with reverence for the energies involved is essential, and should be the foundation for any endeavor in this field. The readings encouraged this approach on numerous occasions. The readings that guided Tim Brown emphasized a service-oriented, ideals-based approach for using science and technology in an entrepreneurial manner – they can serve as a model for any individual who undertakes this quest.

One of the primary strengths of the Cayce approach is its integrated comprehensiveness. Whereas there often seems to be a vast divide between the theories and constructs of modern physics and the day-to-day reality of life on Earth, the Cayce approach attempts to connect the domains of science and technology with the most practical and intimate experiences of daily life and consciousness. Thus, the information in the readings can be a bridge between the questions of ultimate reality, the meaning of life, and the numerous choices and actions that we each must make, every day, in our journey back to the Source. 

Resources

For those readers who would like to delve deeper into Cayce's subtle energy theories and technologies, I have prepared an online resource web page with links to articles and reports on these topics. A.R.E. members can access these resources at: www.edgarcayce.org/technology.

General Extracts from the Cayce Readings

824-1, 20-yr-old man (musician, singer & horn player), 2/11/35

A lover of the beautiful; depicting the beautiful, whether in art, song, music, painting, in dress even. All of these have their influence upon the entity, as would the harmonies of stones; and ever should the entity have about the body the bloodstone, which is - with its vibrations - that element which from the etheronic energies of nature in itself creates the proper environs for vibratory forces about the entity.

500-1, 35-yr-old woman (naturopath), 1/26/34

(Q) Shall I continue to use the [etheronics?] instrument in my work?

(A) When it is found necessary for the development of the individual, well. When it is found that in self there may be the greater good obtained by the own activities, use THAT.

Each soul is a unit, as each corpuscle is a world. Hence they must be met in their OWN field, in their own way. So with the use of instruments or with the use of the faculties or facilities that have been developed in thine own fingers, or in thine own touch, in thine own mind, use that as He hast given thee - depending upon Him, rather than upon someone else, for the directions.

448-2, adult man, 1/28/34

In the matter of the diet we would keep those things that make for rejuvenation to blood and nerve energy in the system; not that making for excess of fats, nor an excess of muscular reaction, but the very natures that should be coordinating and cooperative with the activities of the body, yet that supply those vitamins and elements in the system that those stimulations as are being created will have that assimilated in the body upon which to build.

These are using, then, in the mechanical way and manner, those influences that act upon the material and the mental forces as the etheronic, or the power of spirit manifesting in flesh.

Keep joyous in self. Know that as He has promised there will be given thee as ye need His power to endure, to meet and to overcome whatever may be in thine experience, if ye will but trust in Him. This is both to those who apply and those who receive the applications.

589-3, 41-yr-old man (chiropractor, roentgenologist), 8/24/34

(Q) Is a Radionic analysis a true diagnostic method, or is it just another outfit to fool the patient?

(A) This depends upon the technician with same. The ability may be developed in the technician or physician using same. To one it may be a perfect attunement and get at least eighty percent of correct diagnosis, and to another it wouldn't get ten percent! It is a good instrument, but about one in five hundred will know how to use it!

We would leave it alone, if you are going to use the basic principles and abilities of this man you're asking about - [589] - he knows his business very well anyway! Common sense is better than all the instruments we can make! And he has very good common sense!

1853-2, 35-yr-old woman, 11/28/39

(diagnosis: multiple sclerosis, had already begun using the Wet Cell Battery)

Use also the radionics, but those that are of the nature that will make for equalizing the pulsation in extremities of the body. This as we find may be best done through the use of the Radio-Active Appliance, which is the radionic activity but is that builded or supplied FROM the body-vibrations themselves, by the very nature of the construction of the Appliance. This will ease the tendency of the weakness in the system, equalizing the circulation, especially when the body lies prone, with that existent when the body is erect and in motion.

1397-2, 58-yr-old woman (chiropractor, naturopath), 11/27/37

(Q) My desire is to have sufficient leisure and release from strain to pursue my study and contact with the "rays" which are operating through the various machines now in use - such as radionics, micro-dynameter, aetheronics and others of a similar nature. In order to accomplish this a certain amount of economic security is necessary. MAY I EXPECT THIS TO COME THROUGH MY TEXAS PROPERTY? If so, how soon?

(A) This should rather be, "Lord, is this the channel, is this the manner in which thou would have me serve? If so, then may those channels, in the activities in the Texas lands, be such that there may be provided that security for my giving of myself in the best of my mind and my body to serve in such a way and manner," and LEAVE the results with Him!

These may not be at first, to thee, very definite. But it is HIS way that He would have with thee, if ye would come to know, if ye would be of the greater service in this material experience.

Then, as ye fit thyself in SINCERE desire, so may those channels FURNISH the material things for the carrying out of that He has purposed for thee. And as ye do they will, they WILL supply that needed.

587-5, 45-yr-old woman, 10/10/35

(Q) What is the pain, and the accumulation or thickening, in the right side?

(A) The meeting, as it were, of those congestions caused by poor elimination and poor circulation, as indicated. And these with the other distresses should respond to the applications as indicated.

But keep these periods as holy periods within self, and the activity of the Radio-Active forces - that are the etheronic energies within self coordinating with elements from without, to create the greater balance and make for much better, much more responsive activities in the body.

1402-2, 59-yr-old woman (writer on astrology and numerology), 11/20/37

As we find, as is indicated, there is the need for a revitalizing or reionizing of the energies of the body as associated with the circulatory forces in relationships to the nerves and blood supply, especially.

There are the applications that may be made by the friend, then, whose activities are associated with the etheronic energies; not only the etheronic energies of the electrical forces and their activities through the static and those activities that apply to the body direct, but the mechanical adjustments along portions of the cerebrospinal system as related to the better coordination in the lumbar axis - better especially in the present in the 3rd and 4th dorsal for the reflexes to the secondary cardiac plexus; and the stimulation of the vagus center for the circulation through the throat and the head, the upper portion of the lung and the lung development - or the pleura itself.

These precautionary measures taken in the present may not only overcome this tiredness, these spent energies in the functioning of the nerve forces, but prevent reactions from same that might cause or produce disturbing forces harder to be dealt with.

871-1, 37-yr-old woman (singer), 3/29/35

. . . Yes we have the entity here, [871]; and those relations with the universe and universal forces that are recorded in the records of the entity in time, in space.

In giving that which may be helpful to the entity, in applying what may be given and in correlating the information which may be found recorded here by the activities of the entity in the experiences in the earth and those conditions and phases of the soul's experience in the interim, we find:

The entity should know that the record is as real as is that which may be indicated by that given off as light, for it goes on and on upon the etheronic energies and is recorded upon the film of time and space.

INDEX OF READING 440-1 M 23

Astrology: Jupiter	Par. 7
: Mercury	Par. 4
: Uranus	Par. 7
Consciousness: Christ	Par. 30-A
Doctors: Cold, Paul E.: N.D.	Par. 34-A
Ideals	Par. 5, 6, 11, 16, 30-A
Incarnations: Atlantis	Par. 22--28
: Egypt: Ra Ta	Par. 18--21
: England	Par. 9--11
: Greece	Par. 12--17
Life: Electricity	Par. 33-A
Reincarnation: Groups	Par. 2, 7, 27
Soul Development: Constructiveness	Par. 4, 5, 35-A
: Spirituality	Par. 28
Soul Retrogression: Self-Agrandizement	Par. 5
Vocational Guidance: Science: Electricity	Par. 6, 23, 25, 31-A, 33-A
Will: Astrology	Par. 3
Work: E.C.: Quotations & Similes: "First Find Self"	Par. 5, 30-A, 32-A

TEXT OF READING 440-1 M 23 (Student, Electrical Engineer)

This psychic reading given by Edgar Cayce, New York City, this 14th day of November, 1933.

2. As to the entrance in the present experience from the astrological aspects, as we have noted, this is the cycle when many of unusual abilities - both for good and bad - have entered the environs of the earth, particularly during 1910 - 1911.

3. Then, we find the astrological aspects may be altered materially by the entity's activities in the present experience, as they have been by the entity in other experiences in the earth. However, such influences are as urges, and - with the application of the will of each soul - may be turned into that which is to be constructive or destructive in their experience.

4. The paramount influences in many ways, then, we find from Mercury; hence the mental abilities, the mental activities, the application of self in fields of research of every nature will be of particular interest to the entity. If these are applied along constructive lines, many may call the entity, the individual, blessed. If they are turned into fields of destructive influences, many will rue the periods of contact or association with the abilities of the entity.

5. Hence to each soul would there be given, under such an impelling force, FIND SELF! Know the standards of self's life, the ideals of the mental and spiritual body; that you may be well-grounded in truth, that there may be that which is ever constructive and for the good of the many - rather than for the impelling force that would be for the few, or for self-aggrandizing. For, in self-aggrandizing may come much as to rue the abilities of self.

6. The fields of endeavor, as we find, from this very association, will be in the electrical influences in the experiences of men; and these fields offer the activities for the entity that may make for advancements in the material benefits that may accrue to mankind from the efforts of the entity; particularly in the field of application of things that pertain to the idiosyncrasies or weaknesses and perplexities in the physical body of man. How necessary it is, then, in such applications, for self's ideals, self's standards, to be above reproach, without question in the RIGHT direction!

7. The influences from Jupiter and Uranus make for rather an accentuation in the breadth of activity, and in the abilities to make such influences become very good or very bad. True, as Jupiter is in the descendancy rather than ascendancy in the present, there is rather within the experience of the entity - save through the mental influences in Mercury that appear beneficent to Uranians in the present period - the feeling of being rather "off", or rather undecided as to just how, where, when or what to make self's activities towards in the application in the present experience. Or, as may be termed, physical conditions - of self's judgement as to endanger that activity - occur or cross the mental influences. Yet in the coming season, when Mercury, Jupiter, Uranus and Venus are more in the ascendancy with the Jupiterian influences RULING, that will begin in the latter portion of the coming year (not in the present but in the coming year), there will be an opening of opportunities wherein the entity - and all those that have come into the earth's experience particularly from those environs which have brought such activities in the individual lives of so many in the earth at this time - may give expression to that which has been builded in the experience of the entity in the present, as to the relationship the entity as a soul has builded in its sojourns throughout the activities of the soul; whether in the astrological aspects or from sojourns in the earth itself.

8. As to the appearances, then, and those that make for the greater influence in the abilities and activities of the entity in the present, we will find many experiences of the entity in the earth quite varied in their period of duration and of activity:

9. Before this we find the entity was in that land when there were the gatherings of the peoples in England to make war upon the Colonists in the land of the entity's present nativity.

10. The entity then was among those that were called upon to act in the capacity of arousing the interests in those that would join in their activities to bring about the close, or the rebellious influence in the lives of those peoples. Half-heartedly the entity engaged in the activities, as from being duty bound, in the name Sir Gilbert.

11. In the experience the entity gained little, lost, and lost little; yet the activities were such as to make for those innate desires and abilities within the entity for making associations and contacts that brought THESE in the present experience of the entity; the abilities to decidedly [decisively?] determine questions. While the entity may not be said to be hardheaded, yet - although reasonable - once determined in a line of thought or study, it may hold to same until a more excellent one or way may be shown. This is an excellent quality, an excellent qualification, provided the entity has assured itself as to its standards and its ideals.

12. Before this we find the entity was in that land now known as the Grecian, when there was the returning of those people to their land from the wars in the East.

13. The entity was among those that returned with Xenophon's aid to those that had been lost, in the name then Xertil.

14. In the latter portion the experiences brought much development materially and for the soul activities, through the abilities of the entity to aid those peoples that had been brought to desolation in many ways to find that which would enable them to bring better living conditions in the experience of a depressed - rather than oppressed - peoples.

15. From that builded in the experience, there is in the present the ability for judgements - if the judgements are set in the activity that is of the entity's own awakening; and there are also the interests in those fields of activity particularly that would bring health, hope or life to its fellow man.

16. Keep that ideal, or AMONG those buildings for the ideals in self.

17. And the tentative influence towards being the physician is also from that experience.

18. Before this we find the entity was in that land now known as the Egyptian, when there had been trials and turmoils from the conditions that arose politically and from the religious feeling caused by the banishment of the priest.

19. The entity was among the workers in the native peoples who aided in supplying the peoples those activities that enabled them to apply much of the arts that have been lost to the present day, as to the application of forces from nature in preparing or erecting the buildings in that period. Then the entity was in the name Ptel-in.

20. In such applications the entity was associated with some of the individuals who worked with the king, or the king's council that aided in the building.

21. Hence in the present we find the particular interest in mechanical appliances of the nature that may be turned into those of interest or influence in the lives of individuals; whether pertaining to constructive or destructive influences must be determined in the application of the will of the entity.

22. Before this we find the entity was in the Atlantean periods when much of the destructive forces were being maintained by the religious-political activities (as would be termed) of the peoples in the period.

23. The entity was among those that were set upon to apply their abilities in relationships to the varied conditions that were to be brought about to IMPEL a people to submit to the influences that might be brought to bear. Hence it was

not of the greater constructive influence; yet the abilities may be found in self in the present in the application of mechanical appliances for electrical influences that may bring healing or destructive influences. THEN they were used by the entity, Asal-Sine, as DESTRUCTIVE influences.

24. Hence the warnings that may be given respecting the abilities of the entity, and that to which it may attain, and how, would be:

25. There is set before thee abilities out of the ordinary ken, particularly in those fields of activity that would apply to electrical or gaseous forces applied in electrical emanations that may be builded in the present experience for constructive or destructive forces in their application to the lives of individuals.

26. Then, set the standards high; making sure within self as to the sources of the influences that will bring to the entity the greater blessings in the lives of many.

27. For, (as from the spiritual realm through which the entity has been active,) in the present experience there is - from the spheres - the re-entering or re-birth into the earth's environs of those who were active in Atlantis. From such forces, from such influences, from such sources may the entity be led - and be read - into abilities which, if applied in the proper direction, may make for self in the present experience a soul development that may bring blessings to many, many; and the abilities in self to journey - as is seen off in the eyes, in the soul, in the consciousness of self - within the realm of Creative Forces, ever.

28. For, soul development must come from within. And, if the entity will enter into those fields of activity and association through its studies in these fields, by meditation, there will be pointed out the greater blessings, the greater aid from within self, guided by those influences - not of the mental forces that were blinded in the experience, but: "Let me be tempered rather with the consciousness of the blessings of the Prince of Peace, that may bring hope, harmony and understanding to a soul-sick world."

29. Ready for questions.

30. (Q) How can I best keep in touch with the highest psychic forces that will aid me in fulfilling my purpose in this life?

(A) As may be surmised from that given, there are high soul influences from the activities of the entity in that particular period when MATERIAL things rose to the height not yet attained in the present. Many influences that worked for the advancement or for the destruction are not only entering, but attempting to influence those that were in that environ.

Hence the higher forces that may come through the spiritual influences in the life of the soul may be found by finding first in self, What Is MY Ideal, and in seeking to know that the kingdom is within - and that the standards are those given by the Prince of Peace. If the associations, in seeking into psychic or soul forces in the activities, are ever surrounded by the blessings of the Christ, there may come ONLY good. FAIL not in EVER surrounding self with that environment.

31. (Q) Where would be the best place for me to prepare myself for my life's work?

(A) In the associations of those who are studying the application of electrical forces or appliances as related to benefits that may be had in human life. This

may apply in that from the X-Ray field to the higher and lower voltage influences that may carry the application of medical forces to the bodies of men and women.

There are schools, there are places where such information may be obtained, such connections; and through these channels, as we find, would be the better.

32. (Q) Would you recommend any particular connection or school?

(A) As we would give here, first we would choose within self the particular line of endeavor desired. Then join self, as it were, in the apprenticeship of such an activity. Then, as the studies advance, seek through those channels that present themselves.

For, in soul development as in life development, take the one step at the time. Do not attempt to take the graduate course when the primary is most necessary. For, the basic forces are: First find self, self's relationships, that desired within self for accruing; and in the studies and uses of such influences, KNOW that they are constructive and well-grounded in the faith, in the warp and woof of the very mental forces of the body. Then, these fields of activity will be opened to the body.

33. (Q) How can I best maintain my physical health?

(A) By making application in self of the very principles and influences that may be had from the electrical vibrations.

WE would give, seek that which may be had from the lowest form of electrical forces; and through same apply to the body-principle, the body-forces, that which will keep an even balance in the elements of the body-influences.

These will make for creating that interest, the vision, the activity; for few as this entity may see both the beginning and the end of such actions from electrical influences. For, KNOW, electricity is a manifestation of life principle.

34. (Q) Is the doctor with whom I am now associated a constructive influence in my life? [GD's note: Is he referring to Dr. Paul E. Cold, N.D. whose etheronic instrument is the subject of so much future questioning?]

(A) Not altogether; yet find self, so that in the mental applications of self you may take the good and may judge when destructive forces enter in.

35. (Q) Any other advice or guidance for the body?

(A) Study to show thyself approved unto thy God, and let thy God be ONE; not fame, not fortune, not that which is gratifying only to the desires of a body, but know that if the desire of the heart and soul is grounded in divining truth as it appears in the daily experiences of the life, self may be grounded in Truth. For, HEED that which has been given. Make EVERY act constructive, else those other influences may creep in. KNOW in whom thou hast believed, knowing He is able to keep that thou committest unto Him against any environ, any condition that may arise in thine experience. For, He is in HIS holy temple; and the TEMPLE is within. So meet the first commands, "Thou shalt have no other gods before me," which make for the law of self-preservation; yet if the preserving of self is at the expense of thine brother, thine neighbor, or thine own conscience, ye are setting up other gods! We are through.

REPORTS OF READING 440-1 M 23

See subsequent health and Mental-Spiritual rdgs. answering questions about Dr. Paul E. Cold's etheronic instrument for healing.

RADIONICS/ETHERONICS CIRCULATING FILE

INDEX OF READING 440-3 M 23

[edited]

Appliances: Etheronic	Par. 16-A--24-A
Astrology: Arcturus	Par. 31-A
Diet: Beverages: Wine	Par. 8-A
Doctors: Cold, Paul E.: N.D. : Frischkown, Carl S.: N.D.	Par. 1, 16-A, 17-A, 24-A, 29-A Par. 16-A
Environment: Arizona: Phoenix	Par. 9-A
Gems & Stones: Lapis	Par. 9-A--12-A
Healing: Consistency & Persistency	Par. 6-A
Injuries: Fractures: After Effects	Par. 3-A
Names: Organizations Mentioned: New York Museum of Natural History : People Mentioned: Ringle, A.L.	Par. 9-A Par. 9-A
Nature: Trees: Oak : Persimmon	Par. 13-A Par. 13-A
Numerology	Par. 29-A, 30-A
Physiology & Anatomy: Physiotherapy: Massage: Myrrh : Oils, Olive	Par. 7-A Par. 7-A
Physiotherapy: Massage: Camphorated Oil: Scars : Myrrh: : Oils, Olive	Par. 6-A, 7-A Par. 6-A, 7-A Par. 6-A, 7-A
Prescriptions: Olive Oil: Eliminations	Par. 5-A
Scars	Par. 6-A, 7-A

BACKGROUND OF READING 440-3 M 23

B1. See 440-2 on 12/13/33.

TEXT OF READING 440-3 M 23

This psychic reading given by Edgar Cayce at his home on Arctic Crescent, Virginia Beach, Va., this 18th day of December, 1933.

Edgar Cayce Readings copyright 1971, 1993-2013 by the Edgar Cayce Foundation

1. GC: Body and enquiring mind, also his observations of the work of Dr. Paul Cold of 225 E. 69th St., N.Y.C. You will answer the questions which he submits regarding his own health and work.

2. EC: Yes, we have the body, the enquiring mind, [440]. Ready for questions.

3. (Q) In last reading you mentioned fractures not properly healed. Where are these located?

(A) As we find, that which gives the greater amount of trouble is on the ninth rib area and right side, where with fracture the healing has not absorbed the tendencies of the cartilaginous forces that surrounded fracture at time of healing. Hence that given which would counterbalance the circulatory system to make for the effective activity of those properties in the elements through the diet to complete absorption in body.

4. (Q) Should the body eat roughage such as bran, fruit skins, potato skins, etc?

(A) These have their part in the producing of elements in the system for betterment of general conditions, and in moderation should be taken by the body.

5. (Q) What cathartics are least irritating and most effective in improving eliminations for this body?

(A) Olive oil would be the most effective, taken in very small quantities but often.

6. (Q) Are the scars on the legs or stomach detrimental in any way to the proper functioning of the body?

(A) Little or no hindrance. These may be aided in being removed by sufficient time, precaution and persistence in activity; by the massage over those portions of small quantities at a time of Tincture of Myrrh and Olive Oil, and Camphorated Oil. These would be massaged at different times, to be sure; one one day and the other the second day from same - see? In preparing the Olive Oil and Tincture of Myrrh, heat the oil and add the myrrh - equal portions, only preparing such a quantity as would be used at each application. The Camphorated Oil may be obtained in quantity. Only massage such quantities as the cuticle and epidermis will absorb. This will require, to be sure, a long period, but remember the whole surface may be entirely changed if this is done persistently and consistently. In the massaging, do not massage so roughly to produce irritation. The properties are to be absorbed. Do not merely pat the solution on, but do not use tufts of cotton or other properties to dab it on - dip the fingertips into the solution, and it won't hurt the fingers either - it'll be good for them! and massage into affected portions.

7. (Q) Would an electrical instrument be of assistance in removing the scars?

(A) There are those instruments that may be helpful, but it would require their use in the hands of experienced individuals - and then the results would not be as effectual or as well done as nature's methods in applying properties such as outlined. For, the therapeutic value of the properties given to the skin itself is as follows: As given, as known and held by the ancients more than the present modes of medication, olive oil - properly prepared (hence pure olive oil should always be used) - is one of the most effective agents for stimulating muscular activity, or mucus-membrane activity, that may be applied to a body. Olive Oil, then, combined with the Tincture of Myrrh will be very effective; for the Tincture

of Myrrh acts with the pores of the skin in such a manner as to strike in, causing the circulation to be carried to affected parts where tissue has been in the nature of folds - or scar tissue, produced from superficial activity from the active forces in the body itself, in making for coagulation in any portion of the system, whether external or internal. And, as indicated in the specific conditions referred to in relation to this body, will be MOST effectual. The Camphorated Oil is merely the same basic force [as Olive Oil?] to which has been added properties of Camphor in more or less its raw or original state, than the spirits of same. Such activity in the epidermis is not only to produce soothing to affected areas but to stimulate the circulation in such effectual ways and manners as to combine with the other properties in bringing what will be determined, in the course of two to two and a half years, a new skin!

8. (Q) Are wines harmful to the body?

(A) As indicated, wines - for the stomach sick - are helpful.

9. (Q) Having recommended a stay in Arizona this winter, suggest the most suitable place for the periods mentioned.

(A) Either Phoenix or Prescott, particularly if there is to be the seeking for the indicated conditions in the country. Phoenix, and north and west from there, at not great distances, may be found two or three various deposits of the lapis that may be found to be most beneficial in many of the experimentations in which the body is particularly interested. Ringle, [1/9/34 See 440-11, Par. 25-A saying A. L. Ringle is meant in Phoenix] in this particular portion of the country, is interested in mines of various characters, but don't be carried off by him into gold prospecting, or into the searching for the more precious gems. For, lapis is not considered a high quality of gem; rather a very low form, but for that indicated in the character of the stone itself, it would be most helpful in creating that vibration which will make for developments of certain characters of demonstrations with any psychic forces or psychic individuals.

This may be - will be - a very interesting experiment for the body. Go to the New York Museum of Natural History. Sit by a large quantity of this type of stone and listen at it sing! Do it in the open! Don't let others make a fool of you, or their remarks overcome you - but sit by it and listen at it sing; for it does! It's from Arizona.

10. (Q) Would you suggest any particular ranch in Arizona?

(A) We have suggested here a contact which will not only be all over ranches, but rather a contact that would be very good for seeking out in ANY field of activity!

11. (Q) Describe these stones so that the body may be able to locate them.

(A) Go and look at them in the museum! [See 12/30/33 ltr., 440-3, Par. R3 also 440-9 on 1/3/34.]

12. (Q) How should they be set and cut?

(A) As pendant, either on wrist and worn on body or around the waist.

13. (Q) What results may we expect from such setting and cutting?

(A) Now we are going backwards from what we have given! These, as indicated, are not the channels to be relied upon except in creating the atmosphere.

The same thing may be done with an oak tree, or with a persimmon tree - but the activities that come about are because of the emanations thrown off from the stones themselves to the active forces in the body itself!

14. (Q) We are told [via Mr. [317]'s automatic writing] these stones are located in the Colorado river beds. Is this correct?

(A) They may be found in Colorado river beds, yes - but there's acres of them in other places than river beds!

Now, in connection with these, there may be found others of more precious stones - but DO NOT be carried off to seeking these, because you are going into a country and into a field where LATER the interest may be turned, but not in the particular period through February and March!

15. (Q) Since the body desires to follow the treatment recommended as closely as possible, what locality would you advise for the body during January?

(A) Where he'll be close to those activities in which the indications for the carrying on may be most easily obtainable.

16. (Q) Is Dr. Cold's instrument, designed for [440] of real medical value? a diagram of which I hold in my hand? [See mother's rdg. 443-2 showing diagram of her instrument, page 86 of this file.]

(A) This is rather approached from the wrong angle! It isn't of a MEDICAL value so much as of an ATOMICAL value to the vibrations of the body!

As we find, that set out isn't altogether as proper as might be set. If we would take the same character, though set from a different type of machine, we would rather take that one of Frischkorn's than this! [Carl S. Frischkorn, N.D.] [M.D., D.C.]

17. (Q) Will the construction and use of the instrument suggested for [440] by Cold, a diagram of which I hold in my hand, be of value to others or to him?

(A) If once ever worked out properly! Some of the connections that deal with the emanations must have their rise from a different character of vibration, as we find.

18. (Q) Suggest a more beneficial hook up or method of construction if there be one.

(A) This would require considerable experimentation, though the general basis of the hook up or construction may be given.

These should be set in a more positive or rather a concrete order, see? That is, the activities of the galvanic effect of the vibrations, that make for the production of emanations from the body as related to kindred conditions or bodies, are not in their proper ratio. Then, these once set, there may be added in toto such principles or vibrations that will make for the emanations from the machine that is set to the vibrations of the body, as to neutralize the conditions in the system.

This doesn't say how to hook it up. But there will be required rather the experimentations, so that the galvanic forces from the connections that are made, to find the various areas through which there are the active influences in the system, may be made more concrete, so that they may be pointed out directly on a chart, see, to the body!

Now, when these are once set in this direction, the mineral or vegetable forces may be set in the machine as to issue emanations that will produce the regular rate or ratio of positive and negative force in a body.

19. (Q) Give specific information regarding the construction of the crystal in this machine and outline the theory behind the whole instrument.

(A) The theory is from the atomic vibrations of a body. The constructions of the crystals are those that make for the PRODUCING of that which will show to what portion, and as to what ratio the various portions of the body vibrate one with another. Hence, as indicated, in THIS portion of same, we are in no way near to what is the correct galvanic reaction to it! As to how to cut or prepare the stone for same, as WE would find, rather than the stone the elements that may be combined would be of greater influence. Though the stone may be worked from its activity very good, WE wouldn't work it from that!

20. (Q) What elements would be combined to use in place of crystal?

(A) Uranium, platinite - or platinum in its basic form, and gold (from which the arsenic is taken).

21. (Q) In what proportions?

(A) Uranium three parts. The gold (with the properties in same removed, the arsenic, see?) four parts. The other to complete until ten.

22. (Q) How would they be combined?

(A) In flux. That's in heat, which would be to 280.

23. (Q) Centigrade?

(A) Centigrade.

24. (Q) Are the diagnoses which I hold in my hand correct for date given?

(A) Considering what we have given as to the emanations from the crystal, it would not be from this reasoning, see? From the reasoning shown by Cold's activity, yes. But they are not as effective in bringing the proper balance, as WE find, as may be had with the construction of this machine - making or using as its central point the emanations from these elements. [GD's note: Could this machine have been similar to one later used by D.C.'s called a radionic appliance?].

29. (Q) Dr. Cold gives [440]'s cosmic number as 20. Is this true, and what does it mean?

(A) We would rather say twenty-three (23).

30. (Q) What is the meaning of twenty-three?

(A) A body balanced mentally, physically, spiritually; for it is as the perfect odd number, divisible by nothing - hence perfect in its ratio to one.

Twenty would be rather bad, and would make him rather weak in his feet and in his legs - you see; which, if kept in balance, ISN'T existent!

31. (Q) What is the best substance for induction, conduction, transmission of etheronic energy?

(A) This is as raised power that would be produced from a combination of crystals. This should be rather interesting to this body, for it is very much like that used by the body in the Atlantean sojourn! Not that which caused the cosmic ray, or the death ray, or the healing ray - but the ray that came from setting of the prismatic influences from high heating - it may be from Arcturus or it may be from the Sun; though Arcturus would be nearer proper. The Sun may be induced to make for destructive or constructive forces, either one. It's a combination of those forces or rays that may be gathered in certain setting of

prisms. It would require a lot of detail in preparing same. We would rather refer this to a later period, or seek other channels that may aid with the combination of these.

32. (Q) Is Mr. [317] a good channel [via automatic writing] to seek through?

(A) The better would be through yourself! or we may call other forces in here later, through another sitting. We are through for the present.

REPORTS OF READING 440-3 M 23

R1. 12/19/33 See 440-4, a Mental-Spiritual in re his psychic, soul, development.

R2. See subsequent rdgs. in the [440] series.

R3. 12/30/33 Ltr. to HLC: "I went to the Natural History Museum but could find no trace of a lapis lingua although there were a number of stones enclosed in Case No. 25 of the Morgan Wing with the lapis lazuli. I prefer not to give these names at this time but rather to have your father identify them. They are enclosed in a glass case which makes it impossible, I should think, to hear them sing. Dad [442], however, is going to help me arrange to have the case opened once we are sure which stone has been referred to in the rdgs..."

"The answers are all short but they will be of great assistance to me here in N.Y. at the present moment in my attempt to prove to myself the value of the information which has come through your father."

R4. 1/3/34 Mrs. [255] wrote: "We had a lovely day with young [440]. He brought us all his rdgs. [440-1 through 440-8] and we just talked on them all day. He did not find the stone at Natural History, and asked [275] for a message. She rec'd a message about it (which I do not want to mention because he is going to have a rdg. on it) but at the same time was told not to go in for such questions, because she was not being trained for that work."

R5. 1/3/34 See 440-9 in re lapis.

R6. 1/8/34 See his mother's rdg. 443-3, Par. 19-A in re Dr. Cold's instrument, advising that [440]'s development be alone or "through those influences in self for the present," rather than with the etheronic instrument.

R7. 1/8/34 P.M. See his Ck. Physical Rdg. 440-10, Par. 4-A in re effect of treatment by Dr. Cold.

R8. 1/9/34 A.M. See mother's rdg. 443-5 on Dr. Cold's instrument.

R9. 1/9/34 P.M. See 440-11 in re lapis, follow up on rdg. 440-7, etc.

R10. 1/10/34 A.M. See mother's rdg. 443-6 in re Dr. Cold's instrument.

R11. 1/10/34 P.M. See 440-12 giving further advice on etheronic instrument, recording machine, aurascope, etc.

INDEX OF READING 440-6 M 23

[edited]

Appliances: Etheronic	Par. 26-A
Names: People Mentioned: Sutton, John F.	Par. R2
Psychic Development: Clairvoyance	Par. 2-A
Races: White	Par. 27-A
: Colored	Par. 27-A

BACKGROUND OF READING 440-6 M 23

B1. See 440-5 in A.M. of 12/20/33, and previous rdgs. in the [440] series.

TEXT OF READING 440-6 M 23 (Elec. Engr., Student, Christian)

This psychic reading given by Edgar Cayce at his home on Arctic Crescent, Virginia Beach, Va., this 20th day of December, 1933.

(Body and enquiring mind, together with information already given him on Aurascope, [See 440-3, Par. 25-A--28-A] improvements on Etheronic machine of Dr. Paul Cold and information received through [Mr. [317]'s writing] on static eliminator - drawings and data are being held by [440]. You will answer the questions which he will ask regarding the theory and construction of each of these machines.)

26. (Q) Third, Etheronic machine - drawings in [440]'s hands. Describe the best materials for conduction, induction and transmission of etheronic forces.

(A) These have been given.

27. (Q) What are the proper number of turns of wire upon the coils of this instrument?

(A) These, as we find, would be in ratio to something of the vibration or activity of the vibration of the body itself. This, then, would be necessarily that as would be the general average for the vibrations in the various characters - but this would of necessity mean for white, not for colored - for they would be very different. These would be 3600 revolutions, or 3600 windings.

28. (Q) On which coil?

(A) The inductive.

29. (Q) There are three inductives.

(A) On each one!

30. (Q) What would be the capacity of the condenser?

(A) Sufficient to make for the emanations to raise the vibrations to the individuals to whom it was pointed - in their direction, see? This would reach, or this arrangement would reach for two to two-fifty mils. 3600.

31. (Q) What range of capacities?

(A) From naught to the two hundred. [See Reports, Par. R2.]

32. (Q) Two hundred microfarads?
(A) Two hundred mils.
33. (Q) What is the diameter of the coils?
(A) Sufficient so that the number of wrappings - depending upon the wire or the mil of the wire that is used. These would be two and a half to three inches.
34. (Q) Would these coils be placed as they are in the diagram?
(A) Very little change, as we find, would be necessary as to their position.
35. (Q) Criticize the construction of the aerial.
(A) If these are made rather with the prongs of more pointed and greater in number, as to an upright aerial, be more effective.
36. (Q) Are aluminum and carbon the best substances?
(A) Aluminum and carbon the best substances for sending out, yes - and their ratio of activity or their ratio in the preparation of same would be much as has already been determined for the sending in same. In the inception or reception of same, this may be turned so that they may be had for the induction as well as the influences from without, see? We would change them entirely.
37. (Q) How would you have them?
(A) In loops of copper.
38. (Q) About how large a loop?
(A) If the aerials are raised high, the loops would be three to four inches in each loop; that is, the whole loop measuring around, see; not diameter but circumference.
39. (Q) How many loops would you have?
(A) Four.
40. (Q) How far apart would they be?
(A) Four to six inches, just so there is sufficient of the space for the induction.
41. (Q) Would they be in line with each other?
(A) Be almost in opposites from each other.
42. (Q) At right angles?
(A) At almost right angles.
43. (Q) Would the mixture of elements given last time be placed as the crystal?
(A) Be placed as the crystal. This would necessitate that the elements be MOUNTED in such a way that there are no shorts in same, for these elements are VERY strong in their abilities of the emanations that are sent out, see - especially in uranium.
In this setting of same, it would be practically in the same position - though necessitating, to the carrying of same - that these be so they may be tilted somewhat.
44. (Q) Would you describe more fully the method of connecting?
(A) That from the coils to the induction, or the elements, see? That the mounting for the elements combined in the ratio given be set in such a way that it may be turned somewhat with the directing of forces sent OUT, see? or sort of a swivel.
45. (Q) A condenser of 200 mils is almost impossible to make.
(A) Try this with these elements, and see what it runs to!

46. (Q) With which elements?
(A) Elements as given!
47. (Q) In the crystal?
(A) Elements themselves, as we have given; that are used in the present a crystal, but set so that there are not shorts.
48. (Q) Should the variable condensers be made from these elements also?
(A) Should be made. All the condensers should be made from these elements.
49. (Q) In the proportions given?
(A) In the proportions as outlined.
50. (Q) How many windings on the tickler coil?
(A) One-third of those on the other.
51. (Q) And the capacity of the condenser across the coil?
(A) Sufficient to carry this high a voltage as created by the activity of these.
52. (Q) The last time you recommended a galvanic cell. How would this be connected?
(A) Connected with the condensers and to the coils that make for same.
53. (Q) A little more fully.
(A) Be connected directly to the condenser, see?
54. (Q) Which one?
(A) The central one, through which the coils run.
55. (Q) Is my pen on it now?
(A) The CENTRAL condenser. THAT'S it! We are through for the present.

REPORTS OF READING 440-6 M 23

R1. 12/21/33 See 440-7.

R2. 4/4/64 J. F. Sutton's ltr. to Edgar Evans Cayce:

14-V Hillside Road Greenbelt, Maryland

Mr. E. E. Cayce A.R.E. Headquarters Virginia Beach, Virginia

Dear Mr. Cayce:

Recently I visited Joe Zaboe (I'm not sure of the spelling) at WRC TV in Wash., D.C. He said that a friend of his who moved out of Hungary just before the revolution - mentioned that European scientists, up to the beginning of WW II, used to measure capacitance in terms of units of length. That is, area/distance between the plates distance. This fact would seem to throw some light on an otherwise puzzling reading 440-6, Par. 31-A...which describes a capacitor in the etheronic machine as having a capacitance of 200 mils.

If we use the English system, a capacitance of 200 mils would be two metal plates each one inch by two inches and separated by 10 inches.

However, if we use the metric system, the plates could be one by two centimeters separated by one millimeter. This latter seems reasonable in view of the sizes of the coils described...although the capacitance, probably in the order of 10uuf, would be much less than the turn-to-turn distributed capacitance of the 3600 turns on the coils. At any rate, this all seems much more reasonable than 200ufarad as suggested by Mr. [440] in 440-6, Par. 32-A.

RADIONICS/ETHERONICS CIRCULATING FILE

That's all the information I've been able to dig up about the very intriguing [440] readings - but it's a start. Maybe someday there will be a file of miscellaneous tidbits like this which will add up to some very interesting experiments for the A.R.E research group. Which reminds me - if you can give me some idea of what kinds of research equipment you are interested in, I can probably get some info on what is available.

Mr. Frank Holley at Goddard Space Flight Center is very close to the instrumentation field - he's ordering all of the gear for Nasa's GSFC environmental data reduction and field measurements.

But, personally, I wouldn't even consider buying anything yet - if the lab will not be set up for a few more years - because the instrumentation field is wide open, new developments every day.

Sincerely, John F. Sutton

INDEX OF READING 440-11 M 23

Books: Etheronics: Jeans, James : THE MYSTERIOUS UNIVERSE	Par. 28-A
Diet: Minerals: Iron	Par. 3-A--5-A
Doctors: Biscoe, B. E.: M.D.	Par. R21, R22
Environment: Arizona: Bonita : Casa Grande : Willcox	Par. R9, R29 Par. R29 Par. R11
Gems & Stones	Par. 6-A--14-A
Glands: Leydig: Gems & Stones	Par. 13-A
Life: Balanced	Par. 15-A
Nature: Trees: Psychic Development	Par. 6-A
Physiology & Anatomy: Diet: Minerals: Iron	Par. 5-A
Science: Gravity	Par. 28-A, R31
Time: Budget	Par. 15-A
Will: Astrology: General	Par. 15-A
Work: E.C.: Edgar Cayce: Correspondence	Par. R11

BACKGROUND OF READING 440-11 M 23

B1. See previous rdgs. in [440] series, especially 440-7 and 440-9.

TEXT OF READING 440-11 M 23 (Elec. Engr., Student, Christian)

This psychic reading given by Edgar Cayce at his home on Arctic Crescent, Virginia Beach, Va., this 9th day of January, 1934.

1. EC: Yes, we have the body, the enquiring mind, [440] present in this room, together with the information that has been given this body through these channels.
2. Ready for questions.

3. (Q) Will ironizing the body through the pellets be detrimental in any way?

(A) It will make for a quicker healing and will not produce detrimental effects. As indicated, there would be healing if there is allowed time. If the conditions, the surroundings are such that the body desires quicker activity, then use these that we have indicated.

4. (Q) Should it be taken along with the rest that has been suggested?

(A) Take a pellet each evening.

5. (Q) What is the value in ironizing the body?

(A) Making for those elements or constituents in the blood stream that will make for better, more perfect coagulation in relationships to the portions that have been injured in a manner that makes for the characterization of impossible or impractical in the present condition of producing the proper healing influences to same.

6. (Q) In relation to the lapis, I found a 9000 lbs. stone enclosed in a glass case, etc. Is this the one referred to?

(A) This, as we find, is the one referred to - though it has been moved from its former locations or surroundings, but is in general in the same - AND the stone as referred to.

As there is in the mind of the body, [440] confusions respecting lapis and lapis linguis - it has been given the lapis linguis is that name which was implied to touchstones, or those used by initiates in their various ceremonial activities, and hence gained for themselves through those forces that are seen, as indicated, that they adhere to the activities of those bodies or associations in such a way and manner (the stones, see?) that those that are of a psychic turn may hear the emanations as retained or thrown off by influences about such stones. They are of semi-gem or semi-value to those for other than decorative or for those that have not as yet comprehended, or there has not been admitted by certain fields of activity the value of such stones in relationships to such conditions for those that are not gifted or those that are not so sensitive as to be able to hear those vibrations giving off, or the singing or talking stones - as they have been called in places. Yet, as has been indicated for this body, there should be - there is - the ability within this body, [440], we are speaking of, to hear the singing or the movements, much as in the same way and manner as was given or is given to any if they will listen for days at a growing tree, or as was accredited to and as heard by many of those who have so developed in certain portions of this world as to be able to gain much from especially the growing oak, or certain other trees peculiar to those vicinities. So, in this stone lapis. Lapis linguis is that one that has been in use or in touch with those whose vibrations or emanations or auras are of such natures as to have given those vibrations in the nature that any portion of such a stone may give off that which may be heard, see?

7. (Q) Will it being in a glass case interfere with my hearing it sing?

(A) It should not interfere wholly, though it will not be heard - to be sure - through the glass as definitely as were it separated.

8. (Q) This stone contains malekite and azurite. Is the lapis linguis either of these?

(A) The azurite.

9. (Q) Where will I find this stone in Arizona?

(A) As indicated, about the place as given - in a ranch - a hundred to a hundred and twenty-five miles north to northwest of the place. Many various characters of this lapis may be found in Arizona, as may be of other stones in the same vicinity of a semi-precious value or nature, but those that are of the greater value as the touchstones or those that may receive (we are putting it in another form or manner) a blessing and transmit same to another, or a curse and transmit same to another, will be found in the nature where the greater portion of the azurite is evidenced in the immediate vicinity.

10. (Q) How will I know when I have found this stone that is most useful for my purposes?

(A) When there is found that which is sufficiently clear for the transmission of light and that which may be held in the hand for five to ten minutes and then set aside and listening hear the movements or the vibrations given off from the emanations from self.

11. (Q) Should it be translucent to light?

(A) Should be transparent, or sufficient for the light to pass through.

12. (Q) Should this touch the skin in wearing it?

(A) To be sure. Usually worn, of course, around the neck or over the body close to the vibrations from the heart or from the breast itself in its vibrations.

13. (Q) Would it not be best over the lyden gland? [Leydigian gland?]

(A) Not be best over the lyden gland, for too great emanations from its surroundings might influence the body itself. You are used to influence the stone to an effect, either upon those to whom it may be given or to bring for self the ability to aid in its abilities as raising the vibrations for self. Hence would come over this particular portion, or if desired - for the better in training of self - held over that portion of the hollow on the left side above what is commonly called the collar bone.

14. (Q) What is the best method of cutting, and what metals should be used in mounting?

(A) Use in cutting the ordinary use for the precious or semi-precious stones, in whatever shapes or forms - that are usually the larger in the center and tapering towards the outer edge. Of course, not too large for the use to be worn. The mountings would be white gold or silver. [See Source File Key #440 for A.R.E. Journal article in re Tuaoi Stone.]

15. (Q) Do you find it well for me to drive to Arizona? What days best?

(A) As we find, the conditions that surround such a journey or such a trip would be well to motor - and, of course, the more southern route than going straight across. The days or the periods may be when the body has set self as to the time, as to its activity to meet with itself. Use the days, rather than being used by the days - for the activities in this direction.

This to some may appear to be confusing, with that ordinarily attributed to the value of varied days in individuals' activity or associations in certain directions, as being the astrological activities when the influences would be greater. Influences from astrological make for TENDENCIES, but there is ever the will in the associations of each and every soul.

With this body, as has been given, there is an even balance in self. Not that this does not imply that at the present time something is to be done about it, for to sit still would be to become sterile in the mental or the physical or the activities in even the spiritual or mental development, but to use the abilities. Hence using a cataloging, as it were. First making for self in all of its activities, certain periods for rest, for mental exertion, for mental activity, periods of recreation in the various characters and natures; in other words, budgeting the time, and yet making for advancement not as rote or as just plain routine - but SEE the value in self, in self's development, of so budgeting self and self's activities as to know that the best or the better balance may be kept within self in its advancement in every phase of its mental, physical or spiritual activity. Do not neglect one for another, but to be well balanced is only to be well equipped and doesn't mean movement or activity has begun. The knowledge of self, the knowledge of the various influences in the experience of self is only valuable or constructive when applied in the experience of self. Hence, get busy!

16. (Q) Do you know of one whom I could assist by taking to Arizona?

(A) There may be many that may be suggested. These that would be companionable, helpful - such an one as we would find in House.

17. (Q) To whom do you refer?

(A) House?

18. (Q) Thomas House?

(A) Thomas House! [Thomas B. House, Jr.]

19. (Q) Should I go straight to Ringle on arrival, or would it be well -

(A) As we would find, the better plan would be to first go to Albuquerque, see, and there gain through the research of the genealogy of the activities of all the various forces or sources as applied to the activities in the State respecting that character of stone sought, see? KNOW what this is. This, of course, is not in the same State, but the geography and the greater portion of the minerals of the State may be gained here better, with less excitement of what is being sought by the body, than proceeding to Prescott or Tucson and arousing the curiosity of every one, see? Find it in the adjoining, and then go to the ranch for a period of rest or recuperation and to lay out the plans, and also in Albuquerque gain from Ringle there (this is a different one) the proper connections or associations, and where and how to gain that desired from Ringle in Arizona.

20. (Q) What is the first name of the Ringle in Albuquerque?

(A) Leonna or Cecil, or both of them. [Mr. & Mrs. Cecil S. Ringle.]

21. (Q) In Phoenix? [See 440-3, Par. 9-A on 12/18/33.]

(A) A. L. Ringle.

22. (Q) Is Phoenix the correct address?

(A) From Albuquerque we may get the change in the address, for he is off out on sight or on search, see? [GD's note: I think A. L. Ringle was an uncle of Cecil S. Ringle.]

23. (Q) Who are my associates with the Edison laboratories?

(A) Rather acquaintances there than direct associates that have been, as was indicated that through the acquaintances, through the associates there might be aroused that interest necessary for the carrying on of the portion of the

research desired to be had through these channels. Not so much in the first is there the desire here for the actual in the work itself, but in the preparations for the ground for first information than for associations in the research; for, as given, much of a psychic or spiritual (if it's desired to be given that name) nature may be had not only in self but in the contacts and associations with self respecting the connections there.

24. (Q) Who are the associates with Steinmetz dealing with electrical -

(A) They are they rather who worked with, or who studied or considered with Steinmetz, see? As associated with the activities and research departments of the General Electrical activities in Schenectady and THEIR environ. To be sure, there are offices or channels in New York or in the acquaintanceship or in the associations that may be worked out, see? These we would not hurry; we would not rush. Rather make the inquiries and make gradually the connections; don't rush too hurriedly until you know what you want to present WHEN your associations and connections are established. Work well with that you have in hand in the present. Know that the preparations being made in self between now and April are rather of getting self internally set properly as to its proper way of thinking, of its definite way and manner of finding or presenting these influences in the experience of self, and then these will work gradually into that which will make for the basis of those things in connection with the various things that are of particular interest in the present time, that will make for not only self's being interested in life itself and that it may accomplish but also that accomplished by self may be for the good of many.

25. (Q) What has Steuer written?

(A) As we find, that associated with some of those very things being sought as related to the things necessary for the mental development. As to names, we do not see them here. We would seek those out.

26. (Q) What is Steuer's first name?

(A) S. L.

27. (Q) What is Wallace's first name?

(A) A. V.

28. (Q) Do you know of any books better than those of T. J. J. See regarding etheronic energy, etc.? [See 440-11 Reports, Par. R31--R34 in re T. J. J. See.]

(A) As we find in general, there has been little approach to the subject better than these, but much of a background for the proper understanding of that being presented here is necessary - that may be gained in relation to the influences of the outside world, or in "This Mysterious Universe" or the like, see? [OUR MYSTERIOUS UNIVERSE by Sir James Jeans]

29. (Q) Would you recommend my experimenting with either of the machines given through these sources in the next few months?

(A) Yes, we would experiment with these, in even the open fields when working, when searching, when finding out those things that are being sought. We would find how, when, where these influences may be directed with that you ALREADY have in hand, see?

30. (Q) Which instrument would be the better for this?

(A) That you have had here - last presented.

31. (Q) You find that one better than the one formerly given, when using elements for the crystal?

(A) Well, this one presents a more universal vibration for a more universal effect, while the other may be made for more specific conditions in certain fields of activity. But for the general experimentation and for self in the present, with those changes that have been indicated for the reception or for the transmission through that received or vibrated for or directed to activities in any direction, would be the better.

32. (Q) You have no improvements on the coils?

(A) No improvements on the coils, until there is further experimentation with that especially in the effect upon, or the directing effect upon, plant life.

33. (Q) How will this instrument help locate the azurite?

(A) It would assist in locating the azurite by more of the influence that it would create in those that would contact or raise their own vibrations by the use of same in directing of its activity in other directions, than in pointing out directly the azurite. For, it is turned then from within, you see, to increase - as may be said - the susceptibility in the direction for seeking that which will be as a transmuting or of emanations - for it's quite different in these and in their activity, as will be seen - or these directions for the plants, and we will find there will come to those experiences of the body that which will be the most beneficial for the present.

34. We are through.

REPORTS OF READING 440-11 M 23 [edited]

R2. 1/10/34 See 443-6, his mother's rdg., in A.M. in re instrument.

R3. 1/10/34 P.M. See 440-12 in re instrument, recording machine, aurascope, etc.

R4. 1/17/34 See 442-2, Par. 31-A, 32-A in re instrument.

R5. 1/19/34 See 440-13 & EC's 294-167 (page 121) in re Dr. Cold's instrument.

R6. 2/3/34 Mr. [440]'s wire to EC: "HOUSE UNABLE TO GO. [267] GUIDED TO SAY THAT TRIP SHOULD BE MADE WITH YOU - THAT I SHOULD WAIT HERE WITH THEM [[317] and [267]] AND THE DIFFICULTIES WOULD BE OVERCOME. SUCH WONDERS ARE BEING ACCOMPLISHED BY INSTRUMENT THAT I BELIEVE IN VALUE OF WORK HERE AT PRESENT. SAVE FIRST READING UPON YOUR RETURN [from N.Y.] AND KNOW I AM WAITING HERE WITH THE HOPE AND BELIEF THAT YOU ARE GOING WITH ME."

R7. 2/8/34 See 440-14; 2/13/34 see 440-15; 2/16/34 see 440-16.

R8. 2/27/34 EC left with Mr. [440] for Arizona, GD driving with them as far as Selma, Ala. for a visit to her family. He ret'd on 3/31/34. [See subsequent rdgs. in the [440] series.]

R9. 3/26/34 [440]'s ltr. to EC on [Seventy Six Ranch Bonita, Arizona] stationary:

". . . Upon returning here I found that I was feeling awful and not until today do I again feel like a human being. Something must be taking place inside, or else that high-ball in Mexico was poison. Were you upset? I hope not. I have washed the stone carefully and put it into a handkerchief washed with equal care. Last night, I think for the

RADIONICS/ETHERONICS CIRCULATING FILE

first time I began to hear it. It is curious, it sounded as though it was talking but I was unable to form any words from what I heard, and then do not yet feel certain that it is not just my imagination. I am going up tomorrow to see the collection which Mr. Webb's brother has.

"Last night in browsing through some of the readings, I came upon an answer which has puzzled me. Perhaps it would be best to tell you where you will find it than try to write it out, as it is a long one, and the question before seems to indicate the desirability of experimenting with plants before treating people or do you think it simply refers to establishing the vibration of highest resistance with the cactus. The two questions of which I speak are numbers [32-Q, & 33-Q] in a reading given me on the 9th of January at the Beach. [440-11]

"If it is too much trouble to find the questions or you have not enough time to write, do not bother for while the questions are of interest, they are not of paramount importance. Affectionately, [440]."

R10. 3/30/34 "The instrument is still a puzzle but I shall conquer yet, for I do not believe that it is fair to pass judgment until I know that I am 100% physically, which I am rapidly approaching. Then if I cannot get 23 to 'ring the bell,' there will be good reason to retrace and - find out where the trouble is.

"The vibrations in the stone are becoming stronger every day but as yet I am unable to hear them. They feel much like the Radio-Active battery when I touch the stone.... Your indebted friend," [440]

R11. 4/3/34 EC's letter: "Dear [440]: I suspect that long before this you have come to the conclusion that I must be a very unappreciative individual, not to have said anything to you thus far since leaving Arizona. However, I want to assure you such has not been the case. As I had the opportunity in getting on the train as I did to stop at several places along the way, I did so, as I told you I might. In Birmingham I found quite a group, and also in Montgomery. So, I have been ten days or more getting to the Beach. Consequently, I have been kept so busy that I haven't even had time to write a card, for there were so many funny things happening that would be hard to explain - or believe, almost - that I didn't dare try and tell you about them on postcards, and I didn't have a chance to write any other way - as I was in someone's home all the time when not on the train. But I'll try to review just a bit of it for you, and then you'll know it's either just another tale or a peculiar circumstance that arose during this trip.

"When I left you at Douglas there was a young lady sitting in the seat just opposite me, not more than nineteen or twenty years old - and, of course, I felt she was most too young for me to flirt with (though she cast many glances in my direction, I'll have to admit, and I'm not bragging about that, of course.) Just before we got to El Paso she asked me if she had not seen me in Bisbee the day before; said she thought she saw me with two other men and the mining engineer of the copper mine there. So I told her she was correct. Then she told me she was the daughter of the operating engineer in the mine. I asked her about the azurite and she told me if we really wanted other samples she was very sure that if there was such a thing to be had at all, she would be very glad to get it for us. Her name is Miss Olmsted; whether it's Agnes, Annie or what, I don't know, but should you decide you want other samples I would advise the NEXT time you go to Bisbee that you get in touch with the operating engineer (from what she said about the abilities to get the samples or anything that may be had in that mine.) What do you think of that for coincidence? And I might have had a whole afternoon conversation about it, had I not been trying to not appear too forward or what shall I call it. She apparently knows considerable of the history of azurite that we haven't ever had

RADIONICS/ETHERONICS CIRCULATING FILE

suggested to us. It may be rather in keeping with some of the things our friend Mrs. Dougherty [Myrtle B. Dougherty (Mrs. Fred H.) of El Paso, Texas, spiritualist medium who did voluminous automatic writing.] sent me here. You know we failed to give her our address in Arizona. I'm also enclosing the message she sent to you here. Miss Gladys has typed it so it'll be easier for you to read....

"Later on the same train I met the physician at Willcox, Dr. B. E. Briscoe. Of course, he is well acquainted with all the people at the Ranch, having given treatments to Mr. and Mrs. Johnson and several times has helped out our good friend Smith. (Had he sobered up when you got back to the Ranch?) I talked with Briscoe about the Work, and whether it was curiosity or he gave any credence to it, I don't know - but he is a very good listener. I found that he is a relative of a very good friend of my family in Kentucky.

"All in all, it was a very interesting trip all the way from Douglas to New Orleans....

"I am feeling pretty good. I'm glad that you had a good trip back. It was quite a narrow escape for you that your windshield was broken but it was certainly a godsend that you had shatter-proof glass and there were no bad effects. I'm sure you enjoyed your drive back with Mr. Webb, even if he did go to sleep on you. He is certainly quite an interesting man, and until I crossed the Mississippi River, wherever his name was mentioned in any group or to any individual he was spoken most highly of. Evidently he is quite an influential and well-thought of man in the West....

"I enjoyed every minute of the time I was with you, [440], and most of all I enjoyed our little discussions and readings of the Bible in the evening. I'm sure if you stick very close to that you will be very close to the right way.

"I do hope you are finding the correct relationships with the machine. You realize you'll have to be very sincere with yourself but very consistent and persistent with the attempts to attune your inner self to the cosmic energies that may make themselves manifest through such a machine. It will not be easy at all, for if it is easy then it indeed is much more dangerous - if it has the abilities to do what we are led to believe can be done through it, and what no doubt you are convinced in your own mind it can do from the evidence you have seen with your work here.

"Just yet I haven't been able to look up the reading you refer to, but when I get to that - in the rest of my letter- writing - I will do so and give you my interpretation of the information given there....

R12. 4/9/34 EC's letter, advising that he has just given rdg. 267-2:

"Now, about the reading of Jan. 9th. Answer [Par. 32-A, 440-11], of course, refers only to the coils in the machine and to the use of same on plant life. So, as I understand, would not have anything to do with the present machine, unless it is the attempt on your part to get the vibration of certain plant life as related to 23, or the perfect body; and you will be able to tell whether it adds to or takes from.

"As for locating the azurite with your present machine, as indicated, apparently the use of the azurite would better set YOU to be able to locate it sometime afterwards than in anything else. So, I think the main thing at present is first to satisfy yourself as to the vibrations from 23, as related to your working with the machine. I believe the last information outlined the proper way for you to do this. [See 440-16?] As I suggested while there and in my last letter, I know you realize it must be a very slow but sure and definite thing. Patience and persistence is what you need to practice in your own make-up, and should enable you not only to do something for yourself but to be of greater service to others."

R13. 4/4/34 [440]'s letter to EC: "Before your departure, you expressed the desire for a pair of rabbit's ears which I told you I should try to procure for you. True to my promise, you will find them enclosed. I did not use the gun at all during Holy Week for I went

through a little time of purification with myself in preparation for Easter morning. Yesterday, however, I started out and the first three shots brought down two rabbits, the ears of the first of which I enclose. It was a cotton tail, the other being a jack with huge thick ears which I did not think you would like especially as they were full of wood ticks.

"The people here are all becoming interested in your work and I believe Mrs. Hefflefinger will soon be writing in for a life reading [no rdg.] as she has expressed the intention of doing so. I have tried to tell them about it to the best of my humble ability and kindle their interest. Mrs. Webb [no rdg.] received the pamphlets which you sent and everyone has been studying them with interest. For myself, I am at a loss to know what to think. I rose early Easter morning and went up into a high hill and prayed and waited for the sunrise. I made so to speak 'my skirts clean' with the Father. I know that my life will be an unhappy one if it is not dedicated to some lofty purpose. In my own heart I believe that at-onement with the Creative Forces, which precludes absolute selflessness and the willingness to reflect here on earth their workings from above, in order to maintain that at-onement, is the highest ideal I know and is, from my point of view, the fulfillment of life on earth. As I sat and thought the ideal became clearer and I began to see the different pitfalls of which one must be careful but beyond that nothing happened. All these thoughts I had had before and amounted simply to the clarification of things I already was aware of and cannot therefore be called in any sense a psychic experience.

"I do not feel it was in vain. One never enters into prayer and meditation in vain but the reading promised a psychic experience which never occurred, though I remained on the mountain till the sun was high in the sky. Perhaps I am overly anxious but I long to establish that contact with the infinite and have longed for it since a boy. I had thought that perhaps the readings had indicated a way. I followed them as closely as I was able but the result, at least to date, has been failure.

"I have been disappointed on two other scores also, for as yet, I have not heard the stone sing or talk nor have I obtained any responses from the instrument though I sit for half an hour a day and rub until my arm goes numb on me. The stone however seems to give off vibrations and as I lie in the sun with it on my chest I seem to feel better. This is an experiment I tried and seems to indicate the stone has healing qualities.

"Oh, Mr. Cayce, you are probably angry with me for my inability to fulfill anything the readings have indicated but believe me I have sincerely tried and shall continue to. When things do not work it is no time to quit and because of a few discouragements it is no time to say 'it is all a mistake.' I want to believe in the readings. I feel that there are great possibilities for the future, for a new and enlightened generation and I will NOT give up the ship for the ideal has its foundation on rock though the material realizations fall short of completion time and again.

"Please give my kindest regards to your family and if you feel the present difficulties warrant a reading I should greatly appreciate it, otherwise I shall continue as before. Perhaps I must find my own health first, and thus raise my vibration so that I then have the ability to perceive these things, though I know of plenty of mediums who perceive those on another plane and feel things out of our ordinary range of perception who are not necessarily healthy. The pain in my right side, though still present, is decreasing in intensity and in spite of failures otherwise my health continues to improve for which I am deeply grateful. Health is the first essential. We can accomplish little without it, so I do feel I am doing the first thing first and perhaps should go more slowly with the other things, taking 'one step at a time' as the readings have said.

"Good luck to you. Forgive me for imposing my difficulties upon you but I believe in your sincere interest and await your council with anticipation. Again my regards to your family..."

R14. 4/10/34 EC's letter to [440]: "I have yours of the 4th, and don't know whether I am just fitted to answer this or not - but will do my best.

"Many thanks for the rabbit ears....

"No doubt it was a wonderful experience for you on Easter morning. That you were somewhat disappointed, or possibly wholly so, and feel that the information is incorrect in saying you would have an experience, I am sure is true. But I'm wondering, [440], if you haven't misinterpreted it all. Not that I am trying to insist that you believe in the information that may come through this channel at all; I would never do that, if I know myself, unless one's experience justified it. But isn't it a fact (now analyze yourself a bit) that you have pre-conceived ideas as to what should happen to you as an experience? or haven't you already some idea as to what should take place in your body? Either you have builded this from what you have heard others say as to their experience under such and such conditions, or from what you have read. And the experience must be yours! You must be aware of it. That you don't have it according to your idea, is it any proof to you that it doesn't happen to others - or that it really hasn't happened to you, but you have not become aware of it as yet? And I think the same thing is true respecting the vibrations you should be able to become aware of in the machine. Do these things come so easily that you have no price to pay for them (through your inner self; not in outward things)? Isn't that what is required by all? Or have you some other idea? The promise is there for every one; not because the reading has said so. It has been the experience of every one throughout the ages who has consecrated his life to the service of his fellow man in the name of the living God. Each one has his own individual experience. It may not come at the time or the place or the way you expect it; and you may be as some others I know, 'If I can't have it when I want it, then I don't want it!' Well, do you deserve it - if you really have that attitude? What do you suppose must have been Moses' attitude when he had prepared himself with the most profound education it was possible for an individual to have at the period, and then found he was rejected - and instead of being a leader of his people he went out to lead the poor dumb sheep! [Ex. 3: 1] And he stayed there forty years! Don't you reckon he had just about given up when the call finally came? for he began to make excuses [Ex. 4: 10], yet he knew the promise had been to his people from Abraham's time that they would possess the land and that there would be raised up a leader. Yet he was ready to put it off on someone else. [Ex. 4: 14]

Another could have the experience but he couldn't. The same way with Gideon when he was ready to consecrate and dedicate his life to a service; 'Why, that thing can't be possible!' [Judges 6: 15 and Judges 6: 13--15] It's the experience of us all, [440]; every one that's worthwhile. There are some that want to tell God what sort of experience they want, just what sort of job they want, just what character of person they want to serve, just what line of work they want to do. Is that right? Could you persuade yourself, really, that it is the right way? The information, though it may not be worth a cuss to you, has been worthwhile to others. Of course, I know you are an exceptional fellow, but I hope you are not so exceptional that you won't take advice from something that HAS been really helpful to others. And if it's been to others it can be to you - if you will take it in the way that the Higher Forces or Sources may direct.

"So, I hope you won't lose patience with yourself. Know what you want and pray it through! That's the only way you can do it. Keep on praying, and LIVE every day JUST like you pray!

"The stone stopped singing? In your letter some time ago you said you could hear it - the vibrations in it. I think you may be trying to use it for something that you can SEE, what it will do, rather than listening at what is well for you to do. If it has taken emanations from the cosmic or universal forces, then you may be able to listen and hear

RADIONICS/ETHERONICS CIRCULATING FILE

- even through that channel - what may come to you. If you are trying to see what it will do to you, you may be disappointed all the way round.

"Don't think I am angry with you at all, nor that I am even disappointed in you - as yet. I'm only wondering if you have as much stability as the postage stamp, to stick to a thing until you get there. And you don't have to fool yourself!

"I would not take anything in the world for some of the experiences I had while with you on the trip. Possibly I've enlarged upon them and dreamed of them in my own imagination until I have made them beautiful, possibly more so than they were at that time; but I'm more and more persuaded that what we build in our own imaginations, in our own mental abilities, is much more real than oceans that happen day by day. It at least will stay with us longer, and we can live with it much better than we can some of the things that happen from day to day externally. And life and living is a continuous thing. If we don't put it together and build it from such concepts of spiritual things, the results will not be very beautiful or easy to live with.

"You are so DEFINITE as to some things and so INDEFINITE as to others, [440]. What is truth to you? What is your definition of it? From whence has truth its abilities to evaluate in the experience of individuals?

"That you should find your health is fine, yet I'm very sure that in finding that which will produce health in any animated body you are dealing with the very life essence itself. If you find healing and don't know where you got it, nor where it came from, nor what to do with it, what's the use of having it! You have the most wonderful opportunity before you of any individual I've ever seen or known. But DON'T stumble over it, for goodness' sake!

"I don't know that a reading right at present would help. Possibly after another experience or so, you might be able to get a few questions together. Know this - you may be very sure of it - if it is at all possible for me to use whatever abilities may have been given to me as an aid to you, in the service that I'm sure you CAN render the people at this time, may God grant that I may never lose the opportunity! But if I'm going to cause you to stumble and to doubt, and produce in you any form of disturbance that makes for your questioning the very sources of Life itself because you are confused with what you want and how you want it, God forbid that anything ever be given to you through these channels! It's not an imposition on me, ever, for anyone that is SINCERELY seeking help. But if the information confuses or disturbs that which an individual has found is satisfying to him, the Lord forbid that I ever disturb such a soul! No matter what it may be building; if he is satisfied, I want him to stay satisfied, but I know if he is satisfied he has already begun to fail. What we want is contentment and harmony, that comes only from the listening to the voice from within....

R15. 4/12/34 Card thanking EC for 267-2: "If you have a rdg. for me, ask what the response should be, whether a sound, a vibration in the finger [through the instrument] as if an electric current were passed through it or what. Ask if there is anything I can put on the bakelite sounding board to make the response uniform or to increase it. I still cannot tell the difference between 23 or any other number. Best wishes, [440]."

R16. 4/12/34 letter from [440] to EC: "Your good letter and [267]'s physical diagnosis [267-2] arrived two days ago....

R17. 4/24/34 EC's letter: "I have yours of the 14th. And while I possibly should not attempt to answer you until I have had the opportunity to read Findlay's book, inasmuch as I am not conscious that I have any particular philosophy perhaps I can answer just as well without Mr. Findlay as I can with him, as for the reasons of the faith that is within me....

RADIONICS/ETHERONICS CIRCULATING FILE

R18. 4/25/34 Mr. [440] wrote for a Ck. Physical Rdg. [See 440-17 on 5/3/34] in which he stated:

"Just now, as Dad [442] has said, it seems to me to be the wisest thing, as far as the etheronic instrument is concerned, to start at the bottom and learn first the principles upon which such a machine must be constructed. In the first place, if it is going to take an operator years to learn to operate it [Dr. Paul E. Cold's etheronic instrument], then he must know a lot more about it, what he intends to undertake, than I now know. Secondly, if the instrument has any real value it should be presented to the world by one who knows how to explain its function in practical, tangible, scientific terminology something which I would be unable to do in my present state of ignorance. To hope to have it accepted by the world, this individual should possess the proper degrees to identify him as one capable of discovering such a thing.

"The first thing, then, is to complete my courses in college and, while thus obtaining much valuable knowledge, to also obtain the desired degrees. There is no rush, you can't rush a flower that is going to bloom. If this instrument is truly of value it will come about anyway if not through me then another, and as long as humanity gets it, that is the important thing. Do you agree?"

R19. 4/26/34 He submitted further questions for his Ck. Physical 440-17.

R20. 5/1/34 Letter from [440] to EC from Bonita, Ariz.:

". . . I hope I did not convey the idea that I thought you had a fixed philosophy. In fact my letter was in no way intended to reflect upon your beliefs but was written in response to your advice to me to read the Bible every night if I wished to be on the right path. All my life men have told me this, shouted it from their pulpits, and then in turn made as sad a mess of their lives as one could hope for. It was like waving a red flag in front of a bull. I am sick of seeing where following this advice has brought my fellow man, if reading of the wars and atrocities that have been perpetrated in its name and if being told it was the One Word of God. That is all. I only gave expression to an inner distaste for the person who will read the Bible and accept it as the word of God and then call Marcus Aurelius, Plato and them heathen idlers. I was not criticizing you in any way. I was only presenting a picture for your examination. Had I painted it on canvas it could not have been more impersonal.

"I am in accord with all you have expressed in your letter. I too believe in the teachings of Jesus and bear the deepest admiration of my life for his courage and outspoken words. But I do not believe in being confined to his teachings. The Bible still stands to me as a book of interest. By rejecting it I refer to rejecting the idea that in it alone has God spoken to man, or that it is any more helpful to a seeking soul than thousands of other books.

"I regret that you interpret my words to mean that because a man belongs to the Christian Church I will not help him. I do not care what his faith is. If I can help him, I sincerely pray that the Great Creator grant me the wisdom and strength to do so. But if he be a Mohammedan or Buddhist, I am just as willing to help him as I know you too would be, and am just as willing to learn from him. Of myself, I am nothing nor have I tried to put myself in the position of a teacher. As the artist who feels impelled to paint his thoughts so have I been impelled to write. If the picture does not suit the wall of your room throw it away. My best to all.

"Most Humbly Yours," [440]

R21. 6/29/34 Letter to EC from Dr. B. E. Briscoe of Willcox, Arizona: "On my arrival home, a short time ago, I found your letter and pamphlet, awaiting me, as you suggested

RADIONICS/ETHERONICS CIRCULATING FILE

you would do. I have read them through and have enjoyed reading them, but must confess that it is beyond my imagination or understanding, but it is not the first time in my life that I have met with things or conditions which were a puzzle to me. I don't suppose there will ever come a time when we will all have a complete understanding of the different things we encounter in this world.

"I enjoyed visiting with you very much, and I hope that some day there may be an opportunity, whereby we might be able to meet again.

"I spent a little bit more than eight weeks in New Orleans. It is a very large school and many thousand patients. I got in some very fine work, made many good connections and acquaintances, in fact I don't think I ever had a better time in my life in every way. While there I made arrangements to go as a ship physician on a cruiser to Central and South America. Nothing preventing, I will go some time in August. Of course I am looking forward to the many good people that I am going to meet on this cruise, and the valuable information that I might gain, in addition to the sightseeing part of it.

"Assuring you again that I was very glad to hear from you, and with very kindest regards and best wishes, I am,

"Yours very truly,"

R22. 7/7/34 EC's letter to Dr. B. E. Briscoe, Willcox, Arizona:

"I was indeed very glad to have yours of the 29th. I realize that you were quite busy and no doubt your stay and course at the university did require longer than you at first anticipated, for I am sure when anyone gives of themselves unselfishly to a service for their fellow man little thought is taken as to time or to the outcome save as for others.

"Am happy to know that you had such a wonderful session. I am sure you enjoyed many experiences that were very much worthwhile, and they will prove most valuable to you in the days and years to come in a service to your fellows.

"The idea of your being able to have a Central and South American cruise is certainly most wonderful, and I am in hopes that it all works out just as you anticipate, and I am sure that the associations and contacts in the whole experience will be quite a valuable asset, not only in adding to your material pleasure at this time, but in making for associations and contacts that will be valuable to you in many ways. I rather envy your experience. Wish that it might be possible for me to join you in such an excursion.

"We have just closed our third Annual Congress. This is a 'get together' meeting of our Active Members and friends throughout the country who can find the time and who feel it will be valuable to them to come in closer contact with the sources and channels of information through which this work has come. We had quite a nice meeting this time, the largest in attendance and the most enthusiastic group that we have had thus far. Quite a number of people were present who have been in touch with and who have received benefits from the information, who have known of the work for years, who have not had the privilege of meeting us in person before. We had people from Michigan, New York, Long Island, Georgia, Alabama, Ohio, Kentucky, Washington, D.C. and of course quite a number from Virginia and North Carolina and some other places. We had quite a number of reports from physicians who had cases under their observation, cases that had baffled the profession in many instances. In fact, as I said to you and I think as it should be, very seldom does the individual approach these channels for information until they have tried everything else. Not that this is to take the place of the medical profession - it can't be done. It is only the medical profession who can sign a birth certificate or a death certificate, either, yet there are many of these who make a blunder.

"However, if you would like to see these reports when we get settled down again I would like to send them to you, if you would like to see them.

RADIONICS/ETHERONICS CIRCULATING FILE

"It would be very hard for me to tell you just how close and how much Mr. Little, your uncle and your wife's uncle, meant to me, for in our earliest days he was one of our best friends. He was himself his own worst enemy at times, but indeed a very remarkable and wonderful man, and after all of these years to come in contact, even though for just a moment or a few minutes, with some of his people, it seems to me something has guided these circumstances that would be hard for us as sane people to even put our finger on.

"I know that you are too busy a man to carry on a correspondence, but I will be glad to hear from you, and I am just hoping and trusting that we may find something of vital interest and sympathy between us that we may keep closer in touch with each other.

"With all good wishes to you and yours, I am..."

R23. 9/25/34 Letter from [440] to EC: "The past month has been a most hectic one and finds me today settled in Harvard ready to begin classes tomorrow..."

"At present electrical engineering is the goal and nothing else must be allowed to interfere. Psychic phenomena interests me so much that if I also played around with it, it would have a serious distracting influence."

R24. 10/8/34 "I can honestly say that there is no one in my life, with the exception of my mother, who has helped me to understand better the possibilities that this life may hold, than you. You may find that hard to believe, yet through your readings I have found inspiration for the future and confidence in what I am doing in the present. I question the rdgs., of course, as any intelligent person would do, but you must realize that any criticism or suggestion that I should offer for the work is prompted by my sincere interest in psychic research and my belief that you have the opportunity and the ability to be one of its pioneers... [He requested Ck. Physical 440-19.]

"If you have time to also ask about the feasibility of an expedition next summer to discover definite proof of the existence of the continent of Atlantis, it might prove most interesting."

R25. 11/2/34 EC wrote him about forthcoming rdg. demonstrations before the Psychology Dept. heads at Univ. of Pa. [See 758-38 and 727-1, 11/11/34.]

R26. 12/8/34 Card: "I just read over one of your old letters in which you ask my idea of a tangible demonstration. Such a demonstration would be the discovery or invention of an instrument which would prove the nature of psychic laws at which we only guess at present. Do you think we can do it? That will be the test."

R27. 1/4/35 EC referred him to 5735-1 on 3/27/28 in re machine on which communications might be rec'd from psychic sources.

R28. 1/10/35 "I shall return to college in a couple of wks. to try and complete the 2nd half of the yr... I will have the Harvard laboratories at my disposal for research work in a yr. or so if I am successful in getting my Master's degree." [7/19/35 See 440-20.]

R29. 8/6/73 GD's note to Drs. Gladys & Wm. McGarey, Phoenix, AZ: "At last I have found the name of the ranch where EC stayed with Mr. [440] in 3/34. It was SEVENTY-SIX RANCH, BONITA, AZ, in the next county from Casa Grande, but I'm sure EC and Mr. [440] drove all over that territory while there. Notice attached correspondence [440-11] mentioning prominently some of the people they met while there. Will you tell the lady who spoke out at our lecture, who said there was no dude ranch in Casa Grande in

RADIONICS/ETHERONICS CIRCULATING FILE

1934? I didn't mean to be misleading, but I felt sure it was in that area of Casa Grande where you are now planning the A.R.E. Clinic."

R30. See Source File Key #440 for A.R.E. Journal excerpt from Dr. John H. Sutton's article THE TUAOI STONE - An Enigma, in re Thomas Jefferson See, referred to in 440-11, Par. 28-A.

R31. 7/14/75 Robert J. Jeffries ltr. to Hugh Lynn Cayce:
Dear Hugh Lynn,

My research interests lead me down many interesting (and often blind) alleys. Recently I came across something to which you (or Gladys) may be able to relate.

The reputed situation:

1. There was a man, Mr. "X" (see attached reported data) who did some outstanding theoretical and experimental work toward an understanding of some "psychical phenomena", and in particular, with respect to the existence and nature of an all-pervasive "ether".

2. Mr. "X"'s name, was given specifically (it is reported) and his theories endorsed by Edgar Cayce, and further (it is reported) Cayce said that the works of this scientist would be fundamental to an understanding of "ether" and gravitation.

3. It is further claimed that the Cayce reading which specifically endorsed Dr. "X", by name, is missing from the A.R.E. Library.

4. It is reported that some NASA scientist has written something for A.R.E. regarding energy forces in Atlantis, in which he requests readers to supply any available information with regard to copies of the works of Dr. "X".

I would be interested in:

a. the name of Dr. "X" b. gaining access to any of his "works" c. the name of the NASA scientist and seeing a copy of whatever he wrote.

Obviously I am concerned with anything that is being written or said which links Edgar Cayce to non-medical research, and particularly, everything that the A.R.E. is publishing which directly or indirectly gives credence to "far-out" ideas.

Is there anything you can tell me about any of this?

Cordially, Robert J. Jeffries

R32. REPORTED DATA ON MR. "X"

1. Biography listed in Encyclopedia Americana. 2. Born 1866, Mobile, Missouri; died 1962 Oakland, Calif. 3. Graduate, University of St. Louis (mathematics/physics) Ph.D. University of Berlin, Germany. 4. 1902 joined U.S. Navy as astronomer and teacher of mathematics. 5. Published many articles in German "Astronomische Nachrichten." 6. Retired from Navy 1931. 7. In WHO'S WHO - American Men of Science.

R33. 7/18/75 Gail Cayce's reply to Dr. Jeffries:

Dear Dr. Jeffries:

Hugh Lynn sent your letter of 7/14/75 to the E.C.F. to answer regarding Mr. "X". Yes, there was a man, Thomas Jefferson Jackson See, who did theoretical and experimental work regarding ether. His name was not given by Edgar Cayce but by Mr. [440] in his reading 440-11, Question and Answer 28 asking about his works regarding etheronic energy - and in his answer Edgar Cayce endorsed the man T. J. J. See. The reading is not missing from the library. It can be found under 440-11.

A NASA scientist, Dr. John H. Sutton, Ph.D., wrote an article for the Jan. 1974 A.R.E. Journal entitled "The Tuoai Stone" using Dr. T. J. J. See's information and requesting further information from anyone regarding his previous works.

RADIONICS/ETHERONICS CIRCULATING FILE

We are enclosing a copy of our A.R.E. member C. B. Wynniatt's letter of 6/10/75, from 25 Commins Road, Onerahi, Whangarei, New Zealand, saying that he now has all of T. J. J. See's relevant works, which he lists.

Let us know if you contact C. B. Wynniatt in New Zealand regarding See's works. Perhaps our Library could get a copy of some of them.
Sincerely, J. Gail Cayce

R34. 6/10/75 Letter from C. B. Wynniatt, 25 Commins Road, Onerahi, Whangarei, New Zealand:

"I think that you should also make a note of the fact that T. J. J. See's relevant works, all of which I now have, are: ELECTRODYNAMIC WAVE-THEORY OF PHYSICAL FORCES, vol. 1, 1917; and vol. 2 (NEW THEORY OF THE ETHER), 1922. The 1922 volume is a reprint of 7 papers originally published between 1920 and 1922 in the German astronomical journal, ASTRONOMISCHE NACHRICHTEN.

"8th MEMOIR ON THE NEW THEORY OF THE ETHER, ASTRONOMISCHE NACHRICHTEN, February, 1926. A supplement to the 1922 volume, in which it was not included.

"WAVE THEORY, published in 12 Books, constituting 14 bound volumes (Books 9 and 11 in two parts each), between 1938 and 1954.

"The publishers in all cases were Wheldon & Wesley (England) and Thos. P. Nichols (U.S.A.) (now defunct). They run to a total of about 4000 pages, and are so voluminous because they include a lot of historical and biographical material, and, in the case of the 1938 to 1954 volumes, because they were reproduced from double-spaced typewriting, not typeset. They were printed at See's own expense, this being necessary because his theories were directly contrary to the relativity theories of Einstein."

INDEX OF READING 440-12 M 23

APPLIANCES: ETHERONIC

Books: Dana, James Dwight: MANUAL OF GEOLOGY Par. 22-A, R2

Clairvoyance of E.C.: Incorrect? Par. 22-A

Environment: Virginia: Virginia Beach Par. 31-A, 32-A

Meditation: Preparation Par. 26-A

Names: People Mentioned: Dana, James Dwight Par. 22-A, R2

: Revay, Bob Par. R5

: Ringle, A.A. Par. 21-A

: Ringle, A.L. Par. 21-A

Prophecy: Archaeology Par. 28-A--30-A

: Real Estate Par. 31-A, 32-A

SCIENCE: INVENTIONS: STATIC ELIMINATOR

SYMBOLOLOGY: AURAS: AURASCOPE

Work: E.C.: Psychic Sources Par. 27-A

TEXT OF READING 440-12 M 23

This psychic reading given by Edgar Cayce at his home on Arctic Crescent, Virginia Beach, Va., this 10th day of January, 1934.

2. EC: Yes, we have the entity here, and the enquiring mind, [440]. And this is rather a test for you:
3. We will be able to give you through these channels that in which you may easily demonstrate as to an ability to turn to the akashic records.
4. But work on these that you have. You can use something from the same machine with which you are operating, and let it be recorded on the disc, and then with your amplifier and the magnifier - that may be easily made - PLAY what you receive.
5. Ready for questions.
6. (Q) Is the diagram of the method of attaching aerial to copper plate, which is above the drawer of instrument, as diagramed in the drawing in my hand, correct?
(A) Yes, this will work. It will be correct. This may be made - While it will require more of - This will work with this! Rather we would have prepared one where the aerial is screwed in, rather than just set in. But use it in this as in the first, see.

7. (Q) Does the thickness of the layers of permalloy or bakelite make any difference?
(A) Just so they are uniform.
8. (Q) Both the same thickness?
(A) Both the same thickness. They are uniform in their prevention and their concentration of the influences or forces from the active principles with which this is dealing.
9. (Q) If permalloy layers are round they will have no specific north and south pole. Should they not, therefore, be made oblong?
(A) Not of necessity. For the polarization of same will come, as may have been indicated from that given, more from the coils than from this concentrated center that draws to the activities of same.
10. (Q) Then the permalloy should not be magnetized?
(A) Not necessarily. See, the concentration of the forces through the using - or the differences in the form - is to build up for the carrying into the machine proper, see, that which enables it both to become as drawing in and as emanations in its treatment. To make for it to be magnetized would NEUTRALIZE either the sending or the receiving, see?
11. (Q) Will the magnetic flux of alternate layers of permalloy flow in opposite directions or all in the same direction?
(A) This change as has just been indicated by that just given, is altered or changed by the attuning of same to those influences that are to be aided, or that are in preparation for the aiding of another, see?
12. (Q) Would a quarter inch thickness of permalloy be good for the start?
(A) Quarter inch thickness will be alright.
13. (Q) Would a fan or funnel shape antenna be most effective?
(A) As we would find, the most effective would be that near fan or funnel shape but rather pointed, or - if desired to increase - to make same on the end as of points; that is, two or three - or THREE points in same, see?
14. (Q) Attached to the very end of the antenna?
(A) To the very end.
15. (Q) How long would these points be?
(A) Just sufficient length to make not a diffusion as the forces are received but rather sufficient to each point to be contributory to the other points; or one in center, on either side, inch and a half at the point from the other point - in the point in center, see?
16. (Q) Would copper or a non-conductor be the best material for holding parts of aerial together?
(A) Copper.
17. (Q) Explain in detail how this entity is to tune this instrument in seeking the lapis linguis.
(A) When it is prepared for operation in the open, or the field - best to do it inside, other than - Don't get them too curious about what you're trying to do, with such a curious instrument in the open field the like of this! Evenings will be found better, or close to sundown. Why? The very nature of that being sought - it is, as may be seen from that given, the tendency for a greater activity.

Then, tune first for self, as if it were being prepared for according aid to someone else, see? by using the smear of self's own blood, see? for according the vibration to which self is at that day, or that hour of experimentation, the more sensitive. This is determined by beginning with the twenty-three - that is, for self here, you see - and then listening for that answer that comes through the rubbing that makes for the attraction of the influences from without, see. Then take the lapis that may be already in possession and place same in the box here, you see. Then we gain for self on the other dial the vibration of self at the time to lapis, see? Then when removing same the direction in which there may be pointed by the incoming influence of the effect - of course, it's then necessary that it be moved sufficient distance away - a test piece, see? Then we may find that this will aid in sounding out what may be termed lodes or ledges, rather, of this lapis.

18. (Q) What type of lapis would you use in the box as a sample?

(A) Azure.

19. (Q) Azurite or azure?

(A) Azure.

20. (Q) Do you find for the crystal of this instrument any better substance than carborundum?

(A) This, as we find, would be the better.

21. (Q) Did you mean A. L. or A. A. Ringle in Arizona?

(A) They will both be there! One is the son of the other one!

22. (Q) It is not the intention of the following questions to criticize, but rather to obtain a greater understanding of the source of this information. First, how do you explain the discrepancies in a description of the lapis in the N.Y. Museum of Natural History as to its weight, color and name by which it is catalogued?

(A) Discrepancies? The lapis itself, as is seen, is AS has been given; that there are other minerals or other character of minerals associated with same - Use some imagination! or, as we would give from here, some common reasoning! For, lapis was what was sought for! That's what we were telling you about! That you became associated with same is to be known and used; not used as a criticism nor as a fault-finding. Oft we may find, in seeking through channels of such natures as these, that there are seeming discrepancies - but if there is sought in sincerity that which is aidful, use the aidful to help self and also aid the sources that you are using as a means of gratifying self's own desires. For, when desires of a seeker are in accord with constructive influences, and the information is sought from the channels or sources that may be in the same manner of seeking to aid and help, if such information is used as contradictory - or to produce or bring in self's own mind controversy, the rebound is upon your source of supply. Do not ever hinder or abuse same! This is not as a fault; rather attempting in the same manner that is being asked as to how to be, or to use that which may be given as being sacred! If not, don't seek it, for your own good - for the good of that which may give same! Who, what or where is such being given you in the present? Read the preface to Dana's GEOLOGY! [GD's note: James Dwight Dana, 1813-1895? See 440-12, Par. R2.]

23. (Q) You mentioned obtaining the blue color of the crystal for the aurascope from this stone. There are many shades of blue present.

(A) Use that shade which will come as near being that through which the light may pass in the same manner as it does through the yellow and the red. Of course, the white or the crystal will be that change where, with the rotation of the aurascope prisms, that place where there will be the beginnings of the colors coming into vision as it is slowly turned. Hence to have too deep or too pale a blue (for the blue will be opposite the crystal) - the others then, of course, opposite each other - the yellow, the red. So that in their rotation this becomes as a harmonious effect of all color, as they are formed to the retinae or vision of individuals in the order as they will come from this natural setting.

24. (Q) Would it not be well to mount a fly-wheel on the axis with the crystals, to obtain a uniform rotation?

(A) If mounted in the center, yes.

25. (Q) Should not these crystals be geared up to a higher ratio than that at which the handle turns?

(A) No.

26. (Q) Do you find it would be helpful for me to fast in attempting to contact the Creative Forces?

(A) Rather than designating for an individual as to what preparation should be made by that individual, it is rather the better that the individual concentrate and consecrate its mind, its body, its activities, for a definite service or activity at a given period - and that which is the prompting of that aroused from within for the preparation of such a service, that do.

This may make for a questioning in the mind of the body thus seeking, but know this - my son: It has been given thee that the balance is there. If the self or soul self comes to depend too greatly upon external influences, that are in their nature of coming to thee of thine own source or nature, then it is not self-development. And self-development in its relationship to the Creative Forces, or real generative forces that make for constructive influence in the experience of a soul, is ever the better. For, each soul must come to know its OWN influence and that which is the most helpful. And if it calls then for self to cleanse the body without and within with pure water, or to fast, or to burn incense, or to set about self certain odors or colors of influences, then - as has been given - use these for thine OWN development, but be a seeker and a user of that which thou obtainest. For, not only the hearer but rather the doer gains, in its seeking through to the Infinite forces and influences.

Hence, whether it is desired from the experience to abstain from this, that or the other influence to obtain the better conditions in self, seek to know these - for THOU art not dumb, my brother!

27. (Q) Whom have I had the privilege of having had help me in obtaining the information which has been given through these sources?

(A) These have been rather of the universal; led in their exposition of that given by those in fields of activity akin to that being sought. Not from the lower sources; rather those that have called upon those that were with the beginnings

of elements as they took their place in the manifestations of an all-powerful force that acts in a universe.

28. (Q) Do you think it wise to write the Pennsylvania State Museum, or called University of Pennsylvania, telling them of the crystals they will uncover in Yucatan in order that later they may be interested in an expedition to Bimini?

(A) This would be well. Seek to find, through not divers [diverse] channels but through a regular channel from the university, as to who has led the expeditions in their uncovering and restoration in part (for the better comprehension of that which took place) in Yucatan, and then communicate directly with that leader.

29. (Q) Would you tell us of more that may be uncovered, that we can tell him?

(A) Rather sufficient would it be that there be particular precaution in the uncovering of the stone, or what may appear in the uncovering of what might be termed the sun dial that lies between the temple and the chambers, or OPPOSITE temple - where sacrifices were made. For this is the place, IS the stone - though erosion has made an effect upon same - in which the body will be particularly interested as related to the other forces or expeditions.

30. (Q) In what particular locality in Yucatan is this stone, or these stones?

(A) Where the temples are being uncovered or reconstructed. This has been given, you see.

31. (Q) Do you find it advisable for this entity to buy a piece of land in Virginia Beach at this time?

(A) This is rather to be considered material, and from material standpoint. For, as has been given, MUCH has been outlined as to the advantages and as to the great value of life or activities in this particular vicinity, and the more often would such information - unless considered in the light of ALL that has been given - tend to be rather too great a PERSONAL reason for the INDIVIDUAL through whom such information is being handed you; yet this, if visioned or considered from all given, certainly is not true!

Hence, in considering such at the present time, to be sure, it is a most opportune time for such a purchase; for let me hand you this: One of the first booms will be near Virginia Beach!

32. (Q) Is there any piece of land in particular you would suggest, or any special locality?

(A) As given, that BEYOND 24th street or in that area where the openings of the government activity have begun, will continue to be effective to use.

33. (Q) What caused the battery suggested through these sources for Mrs. [465], which I set up for her, to overflow?

(A) Sufficient space not allowed in the quantity of liquid for the expansion of the liquid when properties act for the raising of the electrical forces. There should be at least two inches allowed for such an expansion.

34. (Q) Was the crock too small?

(A) Too small for the quantity of water put in it, and for the other solution also! This has been given from the first, that all such activities and their preparations should be allowed sufficient expansion - when there is a pound or pound and a half of the copper sulphate and the sulphuric and the activity of the zinc with

same, in creating the forces that come off in the mediumistic form of electrical forces.

35. (Q) When will the next astrological change [as indicated in 443-3, Par. 21-A in re [442]] be that will vitally affect one born on July 16, 1876? [See 442-1.]

(A) The next change that would be - well, there's been a great many since '76, but the next as effective would be in February the 22nd, '34. What is this effect? At that time there begins, for one born on that day (if the hour were given it could be more specific), or very close to same, the rising of the influences in Jupiter, Uranus and Venus, which makes for the influences that are accredited to each in their influence upon human affairs; which would be in this: A period when the mental activities become accentuated for love and for breadth of activity.

36. (Q) Again I thank you for the information which you have given me, and for your patience, and ask your blessing in the name of the Christ, in fulfilling that which you have given me.

(A) May His peace, His blessing, His love, His grace, attend thee in thine seeking. Be up and doing, with a gladdened heart that self may be used as a service - and in a service - to thy fellow man. Be patient. Be persistent, but BE consistent. We are through.

REPORTS OF READING 440-12 M 23

R1. 1/19/34 See 440-13.

R2. GD's note: The Report below is in reference to 440-12, Par. 22-A. Encyclopedia Britannica, Volume 7, p. 28. Copyright 1964 by Encyclopedia Britannica, Inc.

DANA, JAMES DWIGHT (1813-1895), U.S. geologist, mineralogist and zoologist, the author of a number of standard works in his field, was born in Utica, N.Y., on Feb. 12, 1813. He early displayed a taste for science and in 1830 entered Yale college in order to study under the elder Benjamin Silliman (q.v.). After two years as teacher of mathematics to midshipmen in the navy, he was assistant to Silliman in the chemical laboratory at Yale in 1836-37 and then for four years acted as mineralogist and geologist for a United States exploring expedition, commanded by Capt. Charles Wilkes, in the Pacific ocean. In 1844 he again became resident of New Haven, Conn., married the daughter of Silliman and in 1849, on the resignation of the latter, was appointed Silliman professor of natural history and geology in Yale college, a position which he held till 1892. He died April 14, 1895.

A bibliographical list of Dana's writings shows 214 titles of books and papers, beginning in 1835 with a paper on the conditions of Vesuvius in 1834, and ending with the fourth revised edition (finished in Feb. 1895) of his *MANUAL OF GEOLOGY*. His reports on *ZOOPHYTES*, on the *GEOLOGY OF THE PACIFIC AREA* and on *CRUSTACEA*, summarizing his work on the Wilkes expedition, appeared in 1846, 1849 and 1852-54, in quarto volumes, with copiously illustrated atlases; but as these were issued in small numbers, his reputation more largely rests on his *SYSTEM OF MINERALOGY* (1837; subsequent ed. rev. by his son, E. S. Dana; 7th ed. rewritten by C. Palache et al., 1944-51); *MANUAL OF GEOLOGY* (1862; 4th ed., 1895); *MANUAL OF MINERALOGY* (1848; subsequent ed. rev. by E. S. Dana; 17th ed. rev. by C. S. Hurlbut, 1959); and *CORALS AND CORAL ISLANDS* (1872; 2nd ed., 1890). His son, EDWARD SALISBURY DANA, born at New Haven on Nov. 16, 1849, was also a distinguished mineralogist. In addition to his revisions of his father's works he wrote *A TEXTBOOK OF MINERALOGY* (1877; 4th ed., 1932) and *MINERALS AND HOW TO STUDY THEM* (1895; 3rd ed. rev. by C. S. Hurlbut, 1949). From 1879 to 1890 he was professor of natural philosophy at Yale and then was professor of physics until his retirement in 1917. He died June 16, 1935. See D. C. Gilman, *Life of James Dwight Dana* (1899).

INDEX OF READING 440-13 M 23

APPLIANCES: ETHERONIC : Radio-Active: Asthenia	Par. 4-A, 5-A
Bible: Books Of: Galatians 6: 7 : Luke 12: 48	Par. 29-A Par. 29-A
Body: Etheric	Par. 24-A
DOCTORS: COLD, PAUL E.: N.D.	
Gems & Stones: Appliances: Etheronic	Par. 19-A--22-A
Nature: Trees: Appliances: Etheronic	Par. 13-A--16-A

TEXT OF READING 440-13 M 23 (Electrical Engineer, Student)

This Psychic Reading given by Edgar Cayce at the home of Mr. and Mrs. T. Mitchell Hastings, 410 Park Ave., New York City, this 19th day of January, 1934, in accordance with request made by self - Mr. [440].

P R E S E N T

Edgar Cayce; Hugh Lynn Cayce, Conductor; Gladys Davis, Steno. Mr. [440] and Mrs. [443], and Paul E. Cold.

1. HLC: You will have before you the body and enquiring mind of [440], present in this room, and his work on the etheronic instrument present in this room, with improvements suggested in previous information through this channel. You will answer the questions which he has submitted regarding his physical condition, and his work; considering also the work of Dr. Paul Cold, present in this room.
2. EC: Yes, we have the body, the enquiring mind, [440] present in this room; his body and the conditions, the instrument and those suggestions for the improvement, and the work of Dr. Paul Cold. Ready for questions.
3. (Q) Was my recent physical condition a crisis in my treatment?
(A) As to the conditions that have been given, and as to the applications for corrections, that period when the better balance in the general physical forces as related to disturbing influences had been reached. This was to bring to the body the consciousness of the necessary elements in not creating a normalcy for self, but for that work that has been set before self as a factor in determining for individuals and for self as to the channel through which these emanations, these raisings of vibrations in active forces in the body, are necessary. For, to each there is given as they seek, as they show themselves in their activity as being in accord with what they have set as principles, as the ideals before them in relationships to Creative influences in the experiences of all, those steps and those experiences that better fit each individual for that path.

4. (Q) How much longer should I use the Radio-Active battery?

(A) Whenever there is that tiredness, whenever there is that feeling of exhaustion and heaviness, create a balance by the use of those forces with the battery.

5. (Q) Considering the difficulties in obtaining ice in Arizona, should I make a special effort to continue these treatments?

(A) With the activities that have been outlined for the body, as to the preparations of self, as to the conditions in the surrounding country, and as that is a portion of that necessary for the better development, if these are all carried out in unison, the condition should reach the position where they are not - or would not be necessary, see?

6. (Q) Regarding the aerial now on the instrument in this room, do you find the changes have been for the better? Any further suggestions on this?

(A) The aerial itself is for the better, as we find. For, as given, these will enable not only the activities to become more of a centralized but in the manner as directed in the application of the etheronic influences, more specific in their application.

7. (Q) Are the points too far apart?

(A) No.

8. (Q) Regarding the condenser under - to be placed under the aerial being constructed in the rear of the 43rd St. Radio Shop located on 44th St. & Lexington Ave., N.Y.C., it has seemed better to use silicon iron laminations rather than permalloy. Will this work satisfactorily?

(A) While it changes it, of course, the induction of those influences to or through the instrument, as we find, it will work satisfactorily.

9. (Q) Are there any suggestions for building this up in regard to the thickness of the layers?

(A) These have been indicated in that given. And, as has been laid out for construction, as we find, will work most satisfactorily.

10. (Q) Regarding the internal condenser, it so happens that those made of aluminum are of better electrical construction than those made of brass. Will these work as well?

(A) These will work as well and better. For, as indicated, while aluminum in its activity, or in its affinity to etheronic influences, is more easily acted upon, the effects received by those influences to which it is conducted upon the etheronic waves are much more beneficial.

11. (Q) Would it be better to space the laminations or rivet them together?

(A) It has been given for these to be riveted together, see, in instructions.

And, as we find, for the manner in which the experimentations are to be conducted, be very much better that it be - and that they be - riveted together.

12. (Q) I have in my hands a coil wound with nickel wire, rather than aluminum wire. Nickel is somewhat magnetic while aluminum is not. Moreover, nickel wire has a specific resistivity of 6.93 - etc, etc., while aluminum is 2.62. From the point of view of etheronic forces, of what value are these facts?

(A) As indicated in that given respecting the effect upon the receptive influence of etheronic wave forces from such condensations, while aluminum

offers the least resistance and there is the tendency for magnetic influences from the nickel, the effect upon 99% of influences in bodily activity - for which this is being made to be of the better conditions for the active forces in recuperative forces - the greater resistive forces and the higher force as related to creating the magnetic field for activity. And makes for the requiring of a more sensitive application in the operator, in operating the machine. This will be seen by the actual experimentation, that the field with the coil that is wrapped with the nickel, rather than aluminum, will have a greater field of activity through these influences. Hence, as we find from these sources here as being the better to use.

13. (Q) In tuning for plants, do you tune for self first or as we understand set left dial at 12, right at 27, and tune center dial until resonance ceases?

(A) As indicated by the use of the machine in this field of activity, it is to be in the field of the experimentation of how these influences from the radial activity of such an instrument are upon life flow forces. In the matter, or the effect that plant life with its flow of the emanations, or as may be truly called the pith or the flow in the plant itself, is as of the susceptible influences that may be seen in the animal or especially in human life as the closer akin to the effluvia in the lymph of a body. Hence as to how this instrument will act upon plant life by tuning same to self and then used as either a constructive or as tuned to a destructive influence upon plant life gives for the operator a concept and a principle upon how this applied to the human body is MADE to be of greater beneficial value in human life. Just as is considered in some quarters - not wholly correct - that experimentation upon animal life of a nature that propagates more speedily than others, as upon guinea pigs or upon the hare or upon the dog is beneficial in arriving at conclusions as to the effectiveness of induction of forces into the matter, or into the life of the physical forces of man. Here we find with a more perfected instrument to the influences of a universal nature that come closer akin to life itself, or that universal force that we call spirit or God. And when it is realized that that portion in matter that is taken into the body of man from plant life, and from the active forces, is from this very essence that the experimentations are to be made upon, how much more effective, how much closer are the experimenters or operators to the very force or vitality in the body to which the experiments are to be carried for an effectual activity in the affairs or in the life of the body of man itself.

Hence, as indicated in those indications for the use of this upon plant life in specific locations where there are the evidences of the necessity of plant life in that vicinity calling upon nature, not as is known in other environs where that the moistures of the air, where the soil itself that is acted upon by the influences that have come to be known as the means or modes of sustaining life in plant, but rather that as here in this vicinity that draws upon the universal forces themselves rather from the night and the day - that are so close akin to spirit itself. Hence these experimentations must mean in this environ of a greater benefit than were they carried on in others. Yet when the final experimentations, they must be made upon that that is life or FOOD to the body itself. And there will be from the etheronic energy in various foods in the vegetable, in various

fruits as may be seen to be the character of those influencing that to whom the body itself may be applied, see? Hence we have not the mineral that is not possible of being assimilated for a body, but those forces that are of assimilation that work with the etheronic energy gained by the body itself and applicable to the influences for the weal or woe of the body.

14. (Q) Then, as we understand, 12 is not a fixed number on the left hand dial?

(A) These will of necessity find their vibrations as related to the body operator in their application to various elements. And a grade may be made for all of these. This was, as indicated, for an experiment on a particular territory and particular actions in this particular place, for the fact of the greater ability of the reception or receptivity into the machine.

15. (Q) What part of the plant should we place in the drawer?

(A) Any portion that carries within it the life of the plant, whether the root or whether the living force of the body itself.

16. (Q) Should it be there at the same time as the smear, or replace the smear?

(A) If it is being acted upon as that which is of value to the body, with the smear. As it is experimentation on the plant itself, replace the smear.

17. (Q) Have you any suggestions as to the construction of the core of the coil, which I hold in my hand?

(A) As we find, the construction here has been on the right principles and is in accord with that as may be for conducting the better activity through such an instrument.

18. (Q) Would a stronger magnetic core be better?

(A) We do not find it so, for we do not make the magnetic field of such a nature as to draw IN and not be able to send out.

19. (Q) Do you find that the condenser wrapped with the nickel wire will be satisfactory in locating the lapis?

(A) Be satisfactory in locating the lapis.

20. (Q) When tuning for lapis, is the following correct for the entity, [440]? Starting with left hand dial at 23 (smear in drawer), turn toward 0 to point of resonance. If this does not occur, start with 23 and turn toward 100. Now remove smear and replace with sample azurite. Tune right dial for resonance. Now remove lapis and proceed with it in large circle in order to discover points where resonance occurs.

(A) Correct.

21. (Q) If resonance occurs in more than one place, which direction should I go?

(A) That where the resonance, of course, occurs the strongest.

22. (Q) How should the center dial be used?

(A) There may be indicated from the center dial as to the depth or as to the distance in which you will find that producing the resonance.

23. (Q) By the use of thought?

(A) By the use of the very change that comes by the use of the center dial in drawing or pulling to the point of measurement, see? Not only in thought, but rather in the very active principles of that demonstrated by the very production of resonance itself in the fields as indicated, don't you see?

24. (Q) Explain more in detail the settlement "Etheronic energy IS mental control." [GD's note: See 443-5, Par. 18-A on 1/9/34.]

(A) A thesis of 184 pages may be written, my son, on this. But etheronic energy is the emanation from the spirit force through the active force of that which makes for matter being held in its positive position, or in its space of activity. Hence thought as of a body, whether of an animal or a plant, is shown as of plant receiving in its freshness of vigor influences that come from or through the etheronic energy in its activity upon the body, in the expression or upon the plant as in its expression. Hence things that are equal to the same thing are equal to each other.

25. (Q) In grounding a person at a distance for healing, what material should be used?

(A) Copper or nickel? Copper.

26. (Q) Upon what conditions should this be used?

(A) Copper, would be, of course, with the greater principles; for these act with the effluvia of your blood supply. Nickel - more into the nerve reaction.

27. (Q) Would it be well for me to go to ..., Va. and use this instrument on [Mrs. [267]] while waiting for answer from House?

(A) The body, [267], will respond to the use of the machine. It needs it; it has merited it. It would be well, whether waiting - or whether you're waiting with someone else.

28. (Q) Should the north pole of the core be adjacent to the actual north pole?

(A) This the correction.

29. (Q) Is there any other advice or guidance for this body?

(A) As indicated for the body, and for those that have through the giving of themselves in thought and in activity to creating an influence in the experience of others that may mean so much in their expression of their portion of life, remember these carry with them their responsibilities also. Keep self, then, in accord with that thou knowest to be in accord and in the realm of that best within thine self, that thou wouldst have expressed in thine brother. For, as given, "As ye sow, so shall ye reap." For these influences, these forces that are lent to thine own understanding must be returned with those as thine Lord, thine God, would require of thee. For to whom much has been given much is required. Be ye faithful to that thou knowest.

30. We are through.

REPORTS OF READING 440-13 M 23

R1. 1/21/34 See EC's rdg. 294-167 in re use of Dr. Paul E. Cold's etheronic instrument by Mr. [440].

R2. 2/8/34 See 440-14.

INDEX OF READING 440-15 M 23

[edited]

APPLIANCES: ETHERONIC

Healing: General

Par. 9-A

Work: E.C.: Quotations & Similes:
"First Things First"

Par. 9-A

TEXT OF READING 440-15 M 23 (Elec. Engr. Student, Christian)

This psychic reading given by Edgar Cayce at his home on Arctic Crescent, Virginia Beach, Virginia, this 13th day of February, 1934.

(Body and enquiring mind, in regard to his health, and the etheronic instrument or psychonograph and the work that has been done with it in the past few weeks. Ques.)

1. EC: Yes, we have the body, the enquiring mind, [440] present in this room; also the instrument - psychonograph.
2. In the physical forces of the body we find conditions generally show improvements. Those reaction from the activities of the body physically, mentally, those reactions from those things as applied to the activities in the vibrations and those actions that make for the removing of the effects of disorders, show improvements.
3. As to the work that has been done with the instrument, this is very well - as has been given. Rather, however, from these standpoints, we would find it would be well to do the FIRST things first; that there be the application of self as related to that which may be accomplished by the influences in the activity of etheronic energy in the relationships to individuals and that which may be more constructive in their welfare in a material plane. For, as has been outlined, while there may be taken individual cases, individual conditions that are susceptible to the activities of etheronic energy within themselves, irrespective of any application from without, HOW may such be recorded or those experimentations recorded in such a way and manner as to be constructive in the application of same to those that are not sensitive to those very things in their reaction or activity in the body? But when there are begun those activities where there may be recorded from day to day the various actions and reactions to self or to any body experimentations are made upon, as was given, first begin with that which is the basis of etheronic energies in a manifested form - in all forms of its reaction into or to a material body. Then there may be builded in a systematic way and manner that as has been builded, as has been given by the illustrations of those through dissection or the activity of certain principles as from the various energies that are necessary to add to the elements for constructive forces within a body. See?

4. This, as we find, will be the manner in which to make for a condition wherein the body will know what it is doing and what it may EXPECT to be accomplished in the experiences of individuals as they are making for themselves applications for betterments with such an instrument. For, as has been given, it - the instrument - is now where it may be used for constructive and for the basis for removing or bringing to various systems various UNITS of energy that are manifested in a physical body, that which is constructive in their bodies.

5. (Q) Regarding the physical conditions of this body, did the twenty pellets accomplish their purpose?

(A) As indicated, this activity has been to produce a better condition in the body. Now the activities and the association with activities in the body and in relation to those atmospheric pressures, those surroundings that have been indicated, should make for not only the absorption of the disorders but a correction in a way and manner as to eliminate the disorders entirely from the system.

6. (Q) What is causing the pain in the right side?

(A) Where a pressure has existed and it's removed, it's the super-sensitiveness to the body from the removal of the pain. The REMOVAL of that that caused it causes now more pain than the cause itself!

9. (Q) Do you find treatments can be given full force as well as coordinated, as suggested by [Mr. [317]]?

(A) Can be given as well. THIS is the disturbance to the operator under such conditions, however: There will NOT be known as to what to EXPECT when given full force without knowing what a coordinated reaction is. In one manner it may be continually CONTROLLED by the operator. In the other it may not always be controlled. Unless the body so being treated, or the application being made is in accord as to where it may take just what is necessary and leave the rest off. Hasn't self by its own experimentation found that metals themselves may be OVERCHARGED for the better conditions for their operations in activity? Just so in a body, for the body from the electrical standpoint is as a magnet and through the etheronic energy is being accorded the proper vibrations as to make for perfect coordination of all the organs, or all glands, of all functionings in the system. You can overdo it as well as under do it!

So, with the variation from a full charge without being coordinated, SOME may be able to stop! As is set from a charge when there is the activity of the locomotion in those as may be seen from storage batteries (for the body is merely a storage battery now), if this is so set by its own development and its own sensitiveness as to say "click off" when there's enough had - but how can - It's like taking a drink. Can you stop when you want to? Some can, some can't! Be always in CONTROL of that as may be of the most beneficent effects to the human body. You have, as has been given, a most worth while, a most WORTHY thing you are working with, that may bring to thousands life, hope, energy, that will make for a regeneration in the minds and the hearts and the directions of soul forces of human beings. Control it! Don't let it run wild! Begin with the first things first.

Know how it will act upon various elements that supply certain food values to the body in all of its energies, for there may be taken just as well the forces as in the energies that may be supplied in the various elements as has been given that supply certain forces within the body, as those that supply energy in the blood stream, those that build into the bone forces, those that build into the various glands of the system the necessary elements for the activities in a body. Yet if these are taken rather hit or miss, and those energies are supplied without control, what MAY you expect? You have it, yes - but what to do with it, how to control it, how may it be followed systematically! Each and every application is beneficial or detrimental. There is no such thing as saying because it can't hurt you; then if it can't it can't do you good either.

10. (Q) In tuning for self I obtain response from all over the dial.

(A) Is this by the activities of those about the body, or is this from the body-energy itself? How was that given as to how it should be to find the activity of the energy from self, alone or with other elements and energies as powerful or greater even than self? Can you attune or find just what a delicate vibration is from any that would show you the axis or the poles in their vibration beside a large dynamo, or beside a large piece of steel, or even beside the very minutest portion that has already been charged? How has it been given then, my son, to follow instructions? BE wise, not in your own conceit, but in the love that has been shown thee by even giving thee charge of these things that are wonderful in the experiences of men!

11. We are through for the present.

REPORTS OF READING 440-15 M 23

R1. 2/16/34 See 440-16.

INDEX OF READING 440-16 M 23

APPLIANCES: ETHERONIC

Appliances: Etheronic: Specifications and Diagram	Par. R3
Bible: Characters: Aaron	Par. 22-A
: Joshua	Par. 16-A
: Moses	Par. 6, 7
Doctors: Cold, Paul E.: N.C.	Par. R3
: Jacobs, W. Lindsay: M.D.	Par. R3
Kingdoms: Animal	Par. 18-A
: Mineral	Par. 18-A
: Vegetable	Par. 18-A
Names: People Mentioned: Adams, Frank O., Col.	Par. R3
Nature: Plants: Appliances: Etheronic	Par. 17-A, 18-A
Numerology	Par. 20-A
Soul Retrogression: Desire: Carnal	Par. 10
Symbology: Ephod	Par. 6
Urim & Thummim	Par. 22-A
Will	Par. 10
Work: E.C.: Quotations & Similes: "First Things First"	Par. 17-A

TEXT OF READING 440-16 M 23 (Elec. Engr., Student, Christian)

This psychic reading given by Edgar Cayce at his home on Arctic Crescent, Virginia Beach, Va., this 16th day of February, 1934.

1. GC: You will have before you the bodies and enquiring minds of [440], and [294], present in this room, together with the proposed plans for the trip to Arizona. Please give them counsel and advice at this time in regard to the advisability of their making this trip during the latter part of this month. You will consider all circumstances and conditions surrounding both of these bodies and their respective works, and the instrument that will be taken. You will answer the questions which they will ask.
2. EC: Yes, we have the bodies, the enquiring minds, [440] and [294], present in this room.

3. In considering such a trip, which from many standpoints of the work of each would be a desirable thing, all phases should be considered in the light not only of reason but of that which would be the more beneficial in the work that each is interested in and the developments that may come from the associations in the mental and physical manner as would be in such an association or such a trip.
4. As is seen when considered from the light of reason, these are necessary questions that must be answered in the minds of each as to their duties, their obligations, their associations and relations in every sense from the material angle. When taken from this angle, as is seen, there are in the preparations for such an undertaking the necessary preparations for the care of circumstances or conditions during such a sojourn; and as the conditions exist with each, these must be then worked out from an economical and from a phase that would be satisfactory to all concerned. These must be reasoned with from conditions that exist with each, and the determining factor set as to that which is in the mind of each the correct or proper way and manner for same to be handled.
5. As to the physical conditions in the bodies of each, and their associations as related to the instrument that has been given as being of such a value - or may be MADE of such a value in the experience of many, it is as has been said of old in temptations or circumstances that arise in the experience of individuals dealing with factors or conditions that are to make for changes in the experience of the lives of individuals - and especially as to so many that are seen or are imminent in the associations and relations that may be builded up through such a trip or such a period of activity in the mental associations of each: Man shall not live by bread alone, neither shall man consider that there are not others that also depend upon the manner in which their development of individuals has placed them respecting mental, material and spiritual relationships. And if it is as has been maintained and is maintained at all times the One, and must be worshiped from that angle as of One, then others also must be considered.
6. But what of the instrument and that to which it may be prepared - or the manner in which it may be prepared? It is much as that which had to or did stand, for a peoples in the preparations that were given to them, as the pattern in the mount. From the beginning there had been the opportunities for the preparation for the lawgiver, and then through the activities of self was sent into a strange country and among a strange people for those periods of preparation from within self as to make for life - in its expression in the earth - as compatible with conditions in the experience of man in all phases of activity in the earth; beginning with the rod, which may be truly, indeed, represented by that staff that is to take into the machine that which will draw into same those influences by the coordination of activities and elements in the earth, in the air, in the sea, as related to making for elementals or principles that are active in that force which gives to man animation in the form of life in its expression in a physical body. Just as the condensers and the dials, the wrappings, make for the comparisons of those things represented then as the ephod in the experience that was to be worn by him that was to stand between the peoples and their activities in their relationships one to another, and to represent their relationships to their Creator and THROUGH same (the very movements of the ephod itself) did there come to

those waiting peoples the influences that made for their preparations of themselves that through this lineal line there might come the Savior for not only a peoples, a nation, but for the whole world!

7. So, in the preparation of this, it has been outlined for the body to whom it has been entrusted as to the manner of preparation for self in body and in mind, also in the preparations of self respecting the application of things pertaining to the elements through which man is to be made active in those influences that will not only make for the healings of the body as related to the effects as emanations from same in the universal activity in the experience of life but that will bring to them - through the mental activity of the body so operating - as it did with those that had been prepared for this very position of a high priest that was directed by an influence that had been called in the man as the lawgiver who, approaching to the throne of grace in the mount, received then the principles that have been laid down in man's experience since that time as a measuring stick as to man's activity, not only as in his relationships to his God but as in relationships to his fellow man. And they each in their respective activity bring to the experience of man those things that build either for those that become as the fruits of the spirit or those things that make for contentions or strifes or turmoils or wars, that guard, gather and think only of those satisfiyings of the flesh itself.

8. So, when visioned from this angle, may not the association be considered then worth while, in that the mental attitude of each may be made more in accord, that they each in their respective spheres may act as a representative of, or as a shadow of that given as the ways, the means, the manners whereunto there may be given much to a soul-sick world that is crying for the positive associations or expressions of an all-powerful, all-wise, all omnipotent being, as to His thoughts, His relationships, His expressions to the sons of men.

9. Then, when all is considered respecting same, weigh well first those obligations that rest upon one, and the material obligations that would rest upon another, were this made as compatible to the conditions and experiences in the affairs of each. And does this seem in keeping with that as may be the greater accomplishment, then - as he spent the forty years in the preparation - may they spend at least the forty days in their preparations, in their various activities for the needs of many.

10. Then, when these are weighed, choose thou. For, as has ever been, there is no influence that may supersede the will of man; for such are the gifts unto the sons of men that they may make their souls such as to be the companionship with the All-Wise, All-Creative Forces, or separate from them. For, there is no impelling force other than that, "If ye will be my people, I will be your God." It is always thus. And when faults arise, and when temptations come, these are from contemplating on or visioning from those things that would satisfy some activity in the carnal force of an individual. Ready for questions.

12. (Q) If they decide to go, when would be the best time?

(A) When those things that have been promised through the one have been completed in the flesh.

13. (Q) Does that refer to the work of [294]?

(A) What else?

14. (Q) Should they go together, cannot the lapis be picked up without the preliminary study in Albuquerque?

(A) Directions as to what are the best ways and means have been laid out. Choose thou some shorter cut, or some carrying out of other ideas or some other activities, then abide by the results that come from same!

15. (Q) Would it be well for them to go to the 76th Ranch in Bonita, after having located the lapis?

(A) Be very well.

16. (Q) How may the instrument be used to help [294] while in Arizona? What would be the correct adjustment of the dials?

(A) This is not as a fault in anyone, but rather isn't this stepping far ahead or going backward as to what has been pointed out to thee? It has been given as to how each individual may be the better aided by same. Hast thou not also been given as to how and in what way and in what manner the director may prepare, cleanse, make of self the better channel for BEING of the greater aid to each and every one? Draw a comparison, my son, as to what has been given you. Does this not stand much in that same position as illustrated in those days when the people waited? [Exodus 24: 12-18] Though they had seen the Lord Jehovah descend into the mount, they had seen the mount so electrified by the presence of the od of the people and ohm of the Omnipotent to such an extent that no living thing could remain in the mount or on same, save those two [Moses - Joshua] who had been cleansed by their pouring out of themselves to God, in the cleansing of their bodies, in the cleansing of their minds. And yet they tarried only a few days, their cry to the leader was, "We know not what has become of this man. Show us another way. Why cannot we return rather to the gods of the Egyptians. Make thou one that shall lead us, for we know not what has become of this man." [Ex. 32: 1]

Thou hast been shown a way, a perfect way, whereunto thou mayest cleanse thyself, thine body. Why seekest thou to find another god that may lead thee, that is made whether of gold, stone, wood or what not? Why not be patient, my son, and prepare thine self that thou mayest in the very spirit of truth manifest the perfect way. Not a fault in thee, no. Thine overanxiety, or - as was expressed by another teacher - the very zealouslyness of thine self may eat thee up [Psalms 69: 9] and destroy the real value of that thou mayest be in thine zealouslyness trying to do! Oft has it been given, "Stand ye still and see the glory of God." [Exodus 14: 13] Let HIM have His way with thee, that thou mayest indeed know thou art guided step by step with His ways.

Then, as to the healing or the aid, if thou workest together, let HIM guide; not THOU seeking through another channel, or even THIS channel, to do other than He has prepared - or the ways He would prepare thee for the best thou mayest do.

17. (Q) In doing research work with plant life, what effects might I expect in particular?

(A) They must be in particular, and they must be very definite. There is accredited to plant life, and there is seen, as suggested, that which might be used first for determining in self as to what is the flow in plant that does affect self

(for it's self that is working with same, see?) as in relation to those vibrations that are created with the drawing in of the influence into the machine. See? This is the first step. Let's take steps at the time. Do the first things first.

Then, there is taken plant life that bears food values, with its varied values as to its activity in the body of man, that supplies to the building influences in the body the activities known or called vitamins, see? These, then, that are lacking or that are in excess in a body may be shown by that proportion of same as the machine itself vibrates to a human body, which may be attested by the value of each of these vitamin influences from plant life into THEIR RELATIONSHIPS to man. See?

Then, first in self will be the cleansing, through the first of the investigations; self in relationships to the whole of active forces in a material world, through the demonstrations with the plant. Self then will become as one capable, in body, in mind, in purpose, in desire, in spirit, to GIVE to its fellow man that which is of value to their individual lack or excess of bodily conditions, that through the SAME way may be made whole. And then the activity of their development so guided by the purposes, aims and desires of the individual so operating as to lead them - in seeking for themselves - to know the value of the spirit of truth IN THEIR OWN experience. Not that self would make of ANY man a [440] [EC used [440]'s given name] ite, or a [440] [EC used [440]'s surname] ite, or a Cayceite, but a GODLY man in body in mind, in truth! for the GLORY must be to God, not ANY for self.

18. (Q) By elements do you refer to the 97 elements?

(A) Elements referred to in the 97 are rather from the mineral kingdom, while the elements referred to from the vitamin forces are from the plant life. Is man to live upon plant life and its fruit? or is man to live upon the elements in the mineral kingdom?

The mineral kingdom is illustrated in the very machine itself. Plant life and the mineral kingdom are known to man as the lowest form of animation, or movement, in the cycle of activity in an animated form or GROWTH in the divisions. Hence the minerals are used with the man in activity, or living man, which has within himself all the forces that may be seen within the experience of the earth or in any planet, star, or what not, and God included in same! Hence the mineral kingdom and the vegetable kingdom here are used as a balance with the man, that there may be made for him that which will create within his inner physical body (a living organism) that which will create a balance with the universal forces; or mineral kingdom, vegetable kingdom, animal kingdom, terrestrial and celestial - and THESE are they that may be had in self, if thou wilt use these aright!

19. (Q) Is there any book in particular you would suggest telling of the elements of plant life?

(A) Those of any good botanist, as related to food values to the body itself.

20. (Q) Please explain the relation of numerology to etheronic energy as controlled by the tuning of the dials on the instrument.

(A) Again we are following far afield, my son. Let's commence with number one before we come to forty-six!

Numerology has its place, but USE it in its place, as will be seen by there being set for the inference for man upon the dials upon this machine the numbers as related to the relationship between mineral life, plant life and man; BEARING a relationship one to another, see? FIND these by thine experimentations; for is it not to be developed in thee and thine own inner self cleansed, (not to make for getting 23 or 28 or 105 but naught - naught - NAUGHT in self) that ALL may vibrate to that thou mayest be able to obtain from the kingdoms that are manifestations of that etheronic energy or that God-energy in the earth, thou art seeking to use as BENEFICENT effects upon the sons of men!

21. (Q) Is it well to put an electric light in the instrument before using it to warm it up?

(A) A short cut, but it certainly makes for a vitalizing in the metals that is NOT normal!

22. (Q) Which elements in particular would be of the greatest value to observe their effects?

(A) Elements as related to that thou hast in hand, see? That thou hast in hand, as has been so classified, so arranged in their influences as to be active with that thou art going to seek in the other kingdoms and in the mineral kingdom also, through the very activities of those things thou wilt experience in the associations of the experimentation! Dost thou hope in thine self to find in two weeks or two months that it took two men, guided by the Father Himself, eighty years to find? [Moses - Aaron - Urim and Thummim?] Thou art indeed wise, my son, but be not wise in thine own conceit. As God has given, it is a DOING thing to accomplish that. As may be had in thine experience to become worth while, thou mayest accomplish in forty days that as required them forty years; for thou hast an Advocate with the Father through the Christ that will guide thee, if thou wilt but put thy trust wholly in Him and not climb up some other way!

23. We are through for the present.

REPORTS OF READING 440-16 M 23

R1. See subsequent readings in re: health in the [440] series.

R2. See 440-11 Reports.

R3. 11/6/63 Dr. W. Lindsay Jacob [M.D.]'s letter:

W. LINDSAY JACOB, M.D. 360 Van Drive Pittsburgh 37, PA

Mrs. Gladys Davis Turner In care of A.R.E. Virginia Beach, Virginia

Dear Gladys:

I am enclosing specifications and a circuit diagram of the device [etheronic machine] made by Dr. Paul Cold and described in the [440] Series of readings. I obtained these after spending a very enjoyable week-end in ... visiting with Mr. [440].

I talked with Colonel Frank O. Adams when he came through town a week or so ago, and he said that he would relay my request for a complete reproduction of this particular series of readings. I would greatly appreciate obtaining these inasmuch as, now that I have the above-mentioned data, I can make sense out

of many of the readings that were obscure because of this missing data. If for some reason you can't do this at the present time, please let me know; and I will come visiting.

I want to thank you ever so much for your prayers. They must be pretty good. Presently, my personal life is working out without too much difficulty. Thanks again.

Sincerely, W. Lindsay Jacob

11/6/63 Enclosure by Dr. W. Lindsay Jacob -

SPECIFICATIONS FOR THE PAUL COLD [ETHERONIC] MACHINE

The machine is a large wooden box with Bakelite front. The inner dimensions of the cabinet are one foot wide, 6 1/4 inches deep, and one foot one-half inch high. The cabinet is topped by a cylinder (to be described in detail) which is in turn topped by an antenna made of carbon rods, one foot long and one-half inch in diameter. At the top of this carbon rod is mounted in cooper three one-half inch carbon rods that are two inches long and pointed at the ends like a sharpened pencil. These three rods are mounted in a fanlike bracket made of cooper.

The cylinder is seated in a hole in the top of the cabinet, and its copper foot touches the copper plate of the drawer. The outside of the cylinder is Bakelite. It has a copper foot on the bottom which is mounted by a beveled screw that goes through the bottom layer of circular iron discs as well as the bottom of the cylinder. The carbon rod fits into a one-half inch well at the top of the cylinder, which well extends through the outer layer of Bakelite, the first layer of iron discs, and the second layer of Bakelite.

The cylinder is composed of a sandwich arrangement of six layers of iron discs, seven discs (three inches in diameter) to a layer, that are painted black. Each series of seven discs is in turn separated by a Bakelite insulator, approximately one-fourth inch thick.

The outer dimensions of the cylinder are four inches in diameter wide and three and one-fourth inches high. The copper foot extending from the bottom of the cylinder is one inch long and, after approximately one-fourth inch, is cut into a bar approximately one-eighth inch wide. The foot is one-half inch in diameter. It rests on the copper plate over the drawer in the cabinet, and there is also a copper sleeve that separates the copper plate from the top of the cabinet. The plates inside of the cylinder are all resting freely with approximately one-fourth inch between them and the walls of the cylinder. However, the plates at the very top of the cylinder that surround the well for the carbon rod are held in place by a felt ring between them and the outer wall of the cylinder.

On the front of the cabinet towards the top is a small drawer four inches long, three and one-half inches wide, and one and one-half inches deep. It slides in between a one-eighth inch copper plate on top of it and of approximately the same plane dimensions and one-sixteenth inch aluminum sheet underneath it.

Beneath the drawer is mounted a large three-inch coil, inside of which is mounted a two-inch coil, inside of which is mounted an ironbar magnet, circular, three-fourth inches in diameter, and six inches long. The inner end of the

RADIONICS/ETHERONICS CIRCULATING FILE

magnet faces the right side of the cabinet when you are facing it. On the front wall of the cabinet are mounted three variable condensers with rather elaborate scales on them. The two outer ones consist of ten fixed plates and ten movable plates, three inches in diameter. The middle one consists of seven fixed plates and seven movable plates, three inches in diameter. The coils are wound with very heavy copper wire that is about one-eighth of an inch thick and an aluminum wire that is about one-sixteenth of an inch thick. The outer three-inch coil has seventy-two turns of aluminum wire and four turns of copper wire on it. The inner two-inch coil has nineteen turns of copper wire on it. There is a lead of shellacked fine copper wire about the gauge of ordinary bell wire coming from the sixth turn of the inner coil to an iron plate mounted under the detector plate, the dimensions of which are approximately four and one-half inches wide and three inches deep. This iron plate is separated from an aluminum plate by one-fourth inch of wood or Bakelite. The aluminum plate is of the same dimensions.

The detector plate is a Bakelite board mounted three-fourth inches above the aluminum plate.

There is a Carborundum crystal mounted on the side of the cabinet towards the bottom. It is attached to both ground plugs and the aluminum detector plate on one side and the outer terminal of the left variable condenser on the other side. It is labeled as No. 30 Carborundum Detector by the Carborundum Company of Niagara Falls, New York. Its number seems to be ARF45G, price \$1.50 (in 1932).

See circuit diagram as to how the thing is wired (page 72).

See photographs and circuit diagram in re 440-16 (page 71).

RADIONICS/ETHERONICS CIRCULATING FILE

11/6/63 Enclosure by Dr. W.Lindsay Jacob;
re ETHERONIC MACHINE:

440-16 Supplement

- 4 -

Front View



View - Back Removed

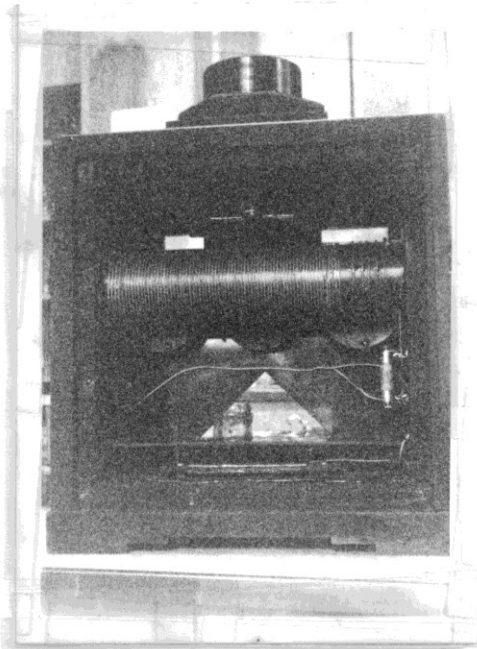

View - Top Removed

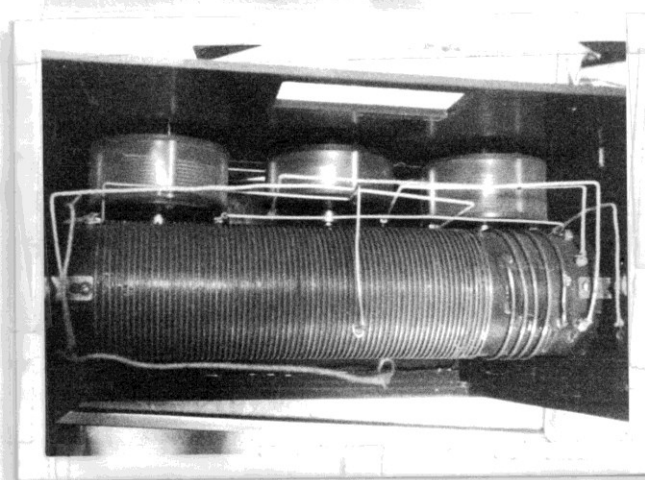

RADIONICS/ETHERONICS CIRCULATING FILE

11/6/63 Enclosure by Dr. W. Lindsay Jacob [M.D.]; 440-16 Supplement
re. ETHERONIC MACHINE:

-5-

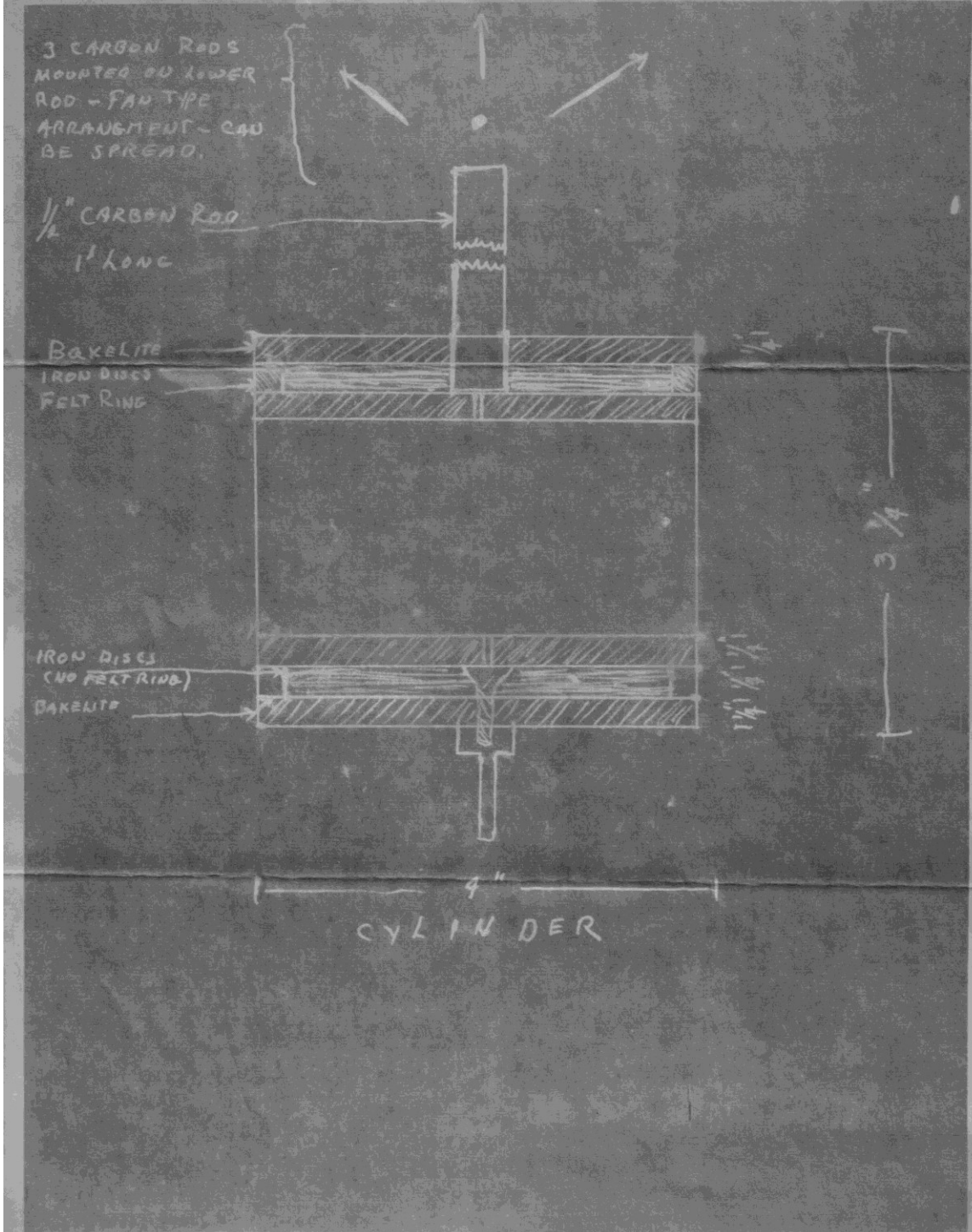

Edgar Cayce Readings © 1971 Edgar Cayce Foundation. All Rights Reserved.

RADIONICS/ETHERONICS CIRCULATING FILE

11/6/63 Enclosure by Dr. W. Lindsay Jacob[M.D.]; 440-16 Supplement
re. ETHERONIC MACHINE:
-6-

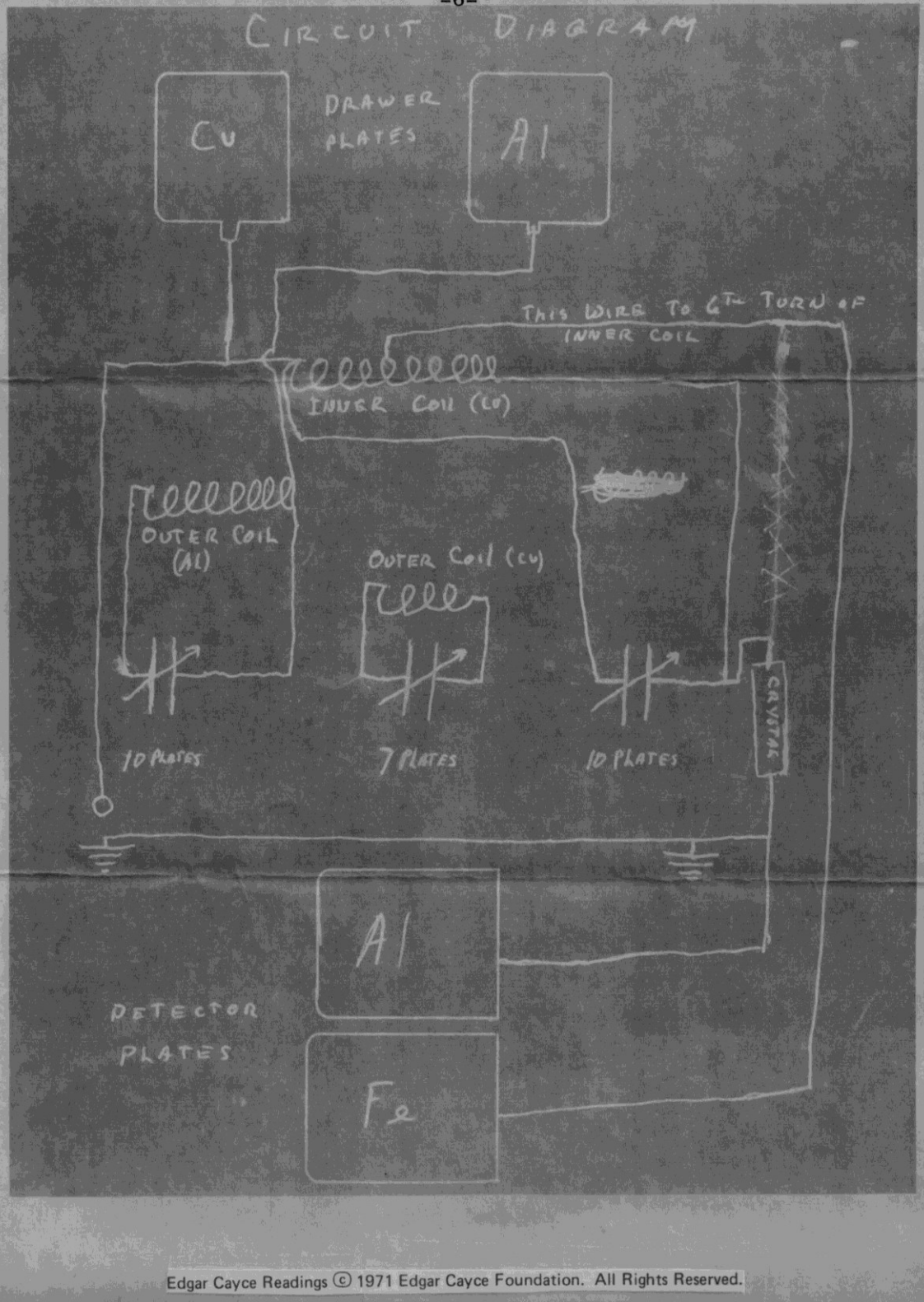

R4. 10/18-19/79 The Beacon, Virginia Beach, Va. [Published thrice weekly w/Ledger Star & Virginian-Pilot] article:

Beach Chiropractor Prescribes Colors, Psychic Vibrations

By Gary Stemm, Beacon Staff Writer

Janet Whittenberg's son suffers from cerebral palsy. Betty Drury's son is mentally retarded. And a Virginia Beach woman who asked not to be identified has a son whose brain is severely damaged.

The three mothers have a common bond in that doctors have told them their sons are beyond medical help. And they have a further bond. They all take their sons to Charles F. Whitehouse, a Virginia Beach chiropractor, for treatment with colored lights and psychic vibrations.

It doesn't matter to them that Whitehouse has been branded a hoaxer and a quack. And they're not worried because Whitehouse is under investigation by state and federal officials because of the treatments he uses.

He uses radionics, which he calls etheronics, and color therapy. Neither treatment is original with him. But he feels the way he is combining them is original.

Whitehouse's theories, according to different opinions, are either hoaxes or potential scientific breakthroughs.

"We disapprove of what he is doing," said Dr. John Jay Krueger, public relations spokesman for the Virginia Beach Medical Society. "We think it's a hoax." Dr. Krueger is even stronger in his personal opinions, calling Whitehouse's work "quackery."

The Virginia Medical Board and U.S. Food and Drug Administration began investigating Whitehouse in 1975 after a complaint from one of his former patients. The FDA became involved since it regulates the use of medical equipment.

A medical board spokesman said recently that the investigation is still active. If the board found Whitehouse's conduct to be unethical, it could revoke his license to practice in the state.

Whitehouse acknowledges that he is being investigated. But he doesn't think it's a very thorough investigation. "They never come in here, talk to me and see what we're doing or check with the people we've treated," he said. He feels that if his theories were scientifically investigated, they would be proven to work.

Mrs. Whittenberg, of Norfolk, says she has obtained results from Whitehouse. Her 3-year-old son, Shannon, she said, has been getting better since she started taking him to Whitehouse for treatment.

"I had gone to so many doctors and hospitals," she said. "He was a vegetable. He did not do anything. They said his brain was deteriorating, and there was nothing they could do. They considered him a terminal case."

On the advice of a neighbor, she took Shannon to Whitehouse.

"I saw results within a month," Mrs. Whittenberg said. "He had only two teeth in his mouth and in one month every tooth had come in. He had stopped growing and he started growing again. He was all yellow but that faded away.

"Now he is very alert, knows everyone in the family and watches TV. I am very pleased."

Mrs. Drury, of Newport News, said she has seen "tremendous improvement" in her 15-year-old son, James, since she began taking him to Whitehouse.

"He remembers better, keeps up school work better, writes better, recognizes more words, and his features are changing," Mrs. Drury said. "Before we took him to Dr. Whitehouse, he was very hyperactive, he tore up everything and he couldn't even tie his shoes.

"After a month of treatment, he suddenly sat down and tied his shoes. And he hasn't torn up anything since. Everyone in the family notices the difference."

Mrs. Drury said doctors told her that James was uneducable and untrainable. But, she said, he is learning more all the time.

"His speech therapist at school is amazed at the difference," she said. "He has started making 100s on every one of his tests."

The Virginia Beach mother said she has been taking her 6-year-old son to Whitehouse since February.

"There's been a lot of progress," she said. "It's a very strange coincidence if it isn't due to Dr. Whitehouse. I'm encouraged by what I see. I'm very pleased. But I don't know that I'm really ready yet to have my name be used."

The woman said she hasn't yet made up her mind about Whitehouse's treatment. "I'm not easily led," she said. "It goes against a lot of things I've been taught. I listened to him explain it and I kept saying to myself, 'I think this is crazy.' Some of it is so bizarre it's incredible. It just doesn't make any sense."

But, she said, she has continued to take her son to Whitehouse because the boy has slowly but steadily been improving. And medical doctors, she said, had told her there was nothing they could do.

She said her son has suffered from brain damage since birth and could do little more than roll over before Whitehouse's treatment.

"He has since become aware of his surroundings, he scoots all over the place, he is starting to relate to people and he is developing a temper," she said. "He still can't walk or talk but he can do a lot of vocalizing with sounds."

Whitehouse specializes in the treatment of the mentally retarded. But he also treats persons with cancer, heart problems and other illnesses. He treats them by shining colored lights on them and bombarding them with psychic vibrations.

Whitehouse charges anywhere from \$50 for a basic three-hour treatment to about \$532 for a complete treatment of body, soul and mind which takes about 300 hours. Since the treatment is basically psychic, the patient doesn't necessarily have to come to his Birchwood Park Drive office. The treatment can be given psychically.

Treatment is available without charge for the mentally retarded through the Etheronics Research Foundation. Whitehouse helped found the non-profit organization, located next to his office, last December for research purposes.

Whitehouse claims a basis for support of color therapy in work being done at the University of Minnesota.

Dr. Douglas Pratt of the university's biology department said he is researching the effect of colored lights on plants. He said he has found that very

deep reds and very deep blues do have an effect on the growth of plants. But he said he knows of no basis for believing it would have the same effect on humans.

Support for Whitehouse's theories does come however, from Dr. William Tiller, chairman of the department of material science at Stanford University. He spent a year investigating the work of George de la Warr, a radionics researcher in Oxford, England.

"My experience is that it is very effective in the hands of the right person," Tiller said during a telephone interview. "Radionics is an intuition training device. Basically, the human being is the instrument and the device helps the individual to attune. The operator is the key, not the device."

Tiller also believes there is promise in color therapy. "There is Soviet work going on right at the moment in which they are shining laser beams at acupuncture points and, depending on the wavelength or set of wavelengths that they use, they are indeed producing healing modalities.

"They're getting rather strong effects of recuperation in people for a whole variety of conditions but it depends very much upon the colors and color combinations they use. And in this particular case, it's laser light."

Tiller said he never had heard of Whitehouse. He said that just because a person uses radionics or color therapy doesn't mean he isn't a "kook." But, he said, both fields deserve scientific research.

"My own feeling is that it's tomorrow's physics," Tiller said. "But my colleagues don't necessarily think that."

- - - - -

Medically banned color therapy not a new idea

Radionics was developed in the early 1900s by Dr. Albert Abrams, a San Francisco physician. His theory was that diseases could be diagnosed by evaluating radiation from the human body.

He devised a machine, the oscilloclast, to measure the radiation. His work was never considered successful but his theories were refined and expanded by other self-proclaimed researchers.

Color therapy also has been advocated for years by self-proclaimed experts. But it has long since been banned as a medical treatment. It is based upon the aura, which according to Virginia Beach chiropractor Charles Whitehouse, is an electromagnetic field which appears to extend about three feet around the human body.

Many occultists believe that people can be trained to see the multi-colored auras. Some say they can diagnose diseases by interpreting the intensities of the different colors and the distances they extend from the body.

Whitehouse says the aura is an electronic duplicate of the physical body. He calls it the etheric body. He has developed a machine, based on radionic principles, which he calls an etheronic analyzer. He says he can measure changes in the concentration of energies in the aura. And, he says, he can measure the strength of the energy coming from any specific part of the body.

He believes that every part of the normally working body radiates a specific level of energy. If all energies are at their normal levels, an individual's etheric

body is in balance. But if the energy levels are either too high or too low, the body is out of balance or in disharmony.

And disharmony in the etheric body, he says, can result in disease in the physical body. Nothing happens in the physical body, he believes, unless it first happens in the etheric body.

Whitehouse believes that by bringing the etheric body, the aura, back into balance, he can treat a physical disease. And, he says, the aura can be brought back into balance by shining specific combinations of colored light on it. Different combinations are used to treat different problems.

To find out what particular energy levels are normal for a person, Whitehouse uses his etheronic analyzer to help him psychically tune himself to that person's mind. He asks the mind what the normal energy levels should be for each part of the body he wants to check. The answer comes in a numerical readout on the analyzer. Whitehouse then concentrates on the specific parts of the body and gets a read-out on what the energy level actually is.

To contact a person's mind, Whitehouse first needs a Polaroid picture of the person. The picture, he says, captures the vibrations from that person's body. He places the picture in a coil in the analyzer, which, he says, helps amplify the vibrations and allows him to tune into the person's mind.

To get a read-out, he rubs one hand on a sensitive plate of the analyzer and starts moving dials on the instrument with the other hand.

Each dial is circled by numbers. His hand rubbing on the plate makes a squeaking sound which increases or decreases in intensity as he moves the dials. When the sound stops altogether, each dial is pointing to a number. The series of numbers is the readout.

The person whom Whitehouse is contacting may be in the next room, or may be miles away. "With the mind, there is no distance," he said.

Whitehouse said that about seven of every 10 persons could be trained to use the analyzer. The key to success is the psychic ability of the operator. "The instrument is an extension of the operator's mind," he said. "It permits you to use your mind to a greater degree than before."

Using the readout, Whitehouse determines what combinations of colored lights are needed to treat a person. If the person is in his office, the treatment is given by actually shining the lights on him. But the patient doesn't have to be there.

Each color of light, Whitehouse said, vibrates at a different frequency. So in place of using lights to treat someone, he can use vibrations. This is done by setting the dials on the analyzer to the numbers which correspond to the vibrations to be used. The picture of the person to be treated is placed in the coil. The vibrations start in the operator's mind and are picked up by the analyzer and transmitted to the patient.

"The machine is a focal point for the operator's sensitivities," Whitehouse said. "You tune your mind and your energy penetrates its energy field. The instrument operates as your mind operates. And it keeps doing the vibration pattern even after you walk away from it."

The vibrations reach the patient's etheric body and "energize it to start vibrating and do what it should be doing."

Before treating a person for any specific illness, Whitehouse first cleans out the person's aura. This is necessary, he says, because the aura may have ruptures or leaks. Ruptures, he says, can occur from such experiences as being administered anesthesia, having an accident, suffering emotional shock or high fever, smoking marijuana or taking hallucinogenic drugs. Ruptures also can be caused, he says, by acute drunkenness. About seven of every 10 persons, he believes, have leaks in their auras.

When a leak occurs, Whitehouse says, a discarnate entity, a ghost, may attach to the person through the ruptured aura. If there are several leaks, a person may have several entities attached to his body. And each entity, he says, places a drain on the body.

With certain combinations of colored lights or vibrations, Whitehouse forces the entities out of the body and seals the leaks in the aura so they can't get back in. Whitehouse believes that his entity theory is the explanation for the phenomenon of possession. He admits that the theory sounds pretty wild and that many of his patients have problems accepting it. "It's a hairy thing that freaks people out," he said.

Whitehouse claims support in his entity theory from what he says was the experience of Dr. George Ritchie, a Virginia psychiatrist. Whitehouse says he heard Ritchie describe an out-of-body experience. The doctor reportedly said he saw entities attaching themselves to people through openings in their auras.

Dr. Ritchie, who lives in White Stone, a town on the Chesapeake Bay north of Tidewater, replied to all questions on the subject with "no comment."

INDEX OF READING 442-2 M 57

[440's father, edited]

Appliances: Etheronic

Par. 30-A, 31-A

ASSIMILATIONS: ELIMINATIONS: INCOORDINATION

CIRCULATION: INCOORDINATION

Doctors: Cold, Paul E.: N.D.

Par. 30-A, 31-A

Life: Balanced

Par. 28-A

NERVOUS SYSTEMS: INCOORDINATION

Throat: Catarrh

Par. 23-A

UREMIA

BACKGROUND OF READING 442-2 M 57

B1. 11/15/33 He obtained a Life Reading, 442-1.

TEXT OF READING 442-2 M 57

This psychic reading given by Edgar Cayce, this 17th day of January, 1934.

2. Now, as we find, there are physical conditions in the body that were there the proper relationships established in the physical functioning of the body we would prevent some disorders as disturb the body, and later prevent much that might be very detrimental to the better physical functioning of the body.

3. While these conditions are of a GENERAL condition in some respects, they are of specific disturbance in other portions of the system, yet with the balancing of the coordinations between the nerve forces of the body with the circulations in such a manner as to make for a coordinated activity in assimilation and distribution for re-vitalizing forces in the body, we would bring better and nearer normal reactions....

23. (Q) What condition is causing the constant collection of mucus in the throat?

(A) That as is indicated by the improper circulation through those portions of the sympathetic cardiac plexus, that makes for the respiratory action through those portions of the system as indicated. These will be clarified by completing the circulation, or coordination of circulatory activities through the sympathetic and cerebro-spinal in this particular portions of the body. Caused, as indicated, by that as has produced that as forms the character of scar tissue reaction. It is more as of tissue burned by temperature, fever, and especially by the activity on the muco-membrane circulation by those of bacilli, of cold, congestion, flu, or the like....

28. (Q) Are any physical, mental or spiritual conditions apparent in this body which need correction or purification for it to be in healthy and receptive condition as a constructive channel for development of the higher psychic faculties?

(A) The physical conditions, as indicated, need corrections, as to how they may be the more easily reached without causing strain to other portions of the body, with the nearer normal physical body the mental - as well as the spiritual forces have the better channel for their activity or manifestations. The mental body is well balanced, as has been indicated. The spiritual are ever ready for manifestation, when there is given the opportunity. Does the mental and the physical war with those of spiritual influences, they make contending forces within the body; thus affecting the body through the impulses of the whole body as a whole.

With the corrective forces, with keeping the body-physical and mental well balanced, there will be made for the better soul or spiritual development, and make life in its manifestations in the self more worthwhile....

30. (Q) In physical and psychic treatments given this body by Dr. Paul E. Cold with his instrument, Dr. Cold has established this body's cosmic number as number 9. Is this correct?

(A) Most too low for this body. As has been indicated in the activities, these should be worked with any of those of the psychic forces as from 23. While true the physical resistances in the system have been low, but - as we would find - the vibrations from those of psychic influences would vibrate for this body nearer from 14 or 15 than from than from 9. Six is a natural consequence in numbers for most any disturbances where those of the properties or elements are disturbed where low vibrations have been, but 9 for this body is too low.

As we would find, these of the psychic forces from those of the vibrations from those applications as may be made in the cosmic forces from atomic influences in the system may be better as a preventative than curative for this body.

For, were the coordinations established, these would be the influences that would aid most or be the more helpful. We would do this, as has been outlined.

31. (Q) What is the significance of the 14 or 15 in relation to this body?

(A) As to that as to which the vibrations will make for the better of raising the resistances for the building up of the body, see?

As has been indicated, these we would NOT disturb or use until a better coordination has been established.

REPORTS OF READING 442-2 M 57

2/21/34 Dr. Frank P. Dobbins' letter:

"Mr. [442] has shown a marked improvement. The amount of mucus has diminished. I consider this remarkable in view of the fact that he has had a most annoying head and throat cold. He feels very much encouraged. I shall not see him now for two or three weeks as he is going to join Mrs. [443] in Florida.

4/12/34 Son [440]'s ltr.: "Mother [443] still admits that Dr. Paul E. Cold's instrument may work. This sudden change of opinion on her part, however, about Cold, has produced a most unfortunate turn of mind on the part of my father [442]... Mother's change of mind seems to have again strengthened [442]'s doubts as to everything I am doing and am interested in [in re Dr. Cold's etheronic instrument, etc]."

INDEX OF READING 443-2 F 45

[440's mother]

Appliances: Etheronic : Radio-Active: Cysts	Par. 20-A Par. 16-A, 19-A
Arts: Creative: Writing: Inspirational	Par. 18-A
CYSTS	
Doctors: Cold, Paul E.: N.D.	Par. 20-A
Meditation: Psychic Development	Par. 21-A
Mind: The Builder	Par. 12
Physiology & Anatomy: Prescriptions: Bismuth, Milk of : Magnesia, Milk of : Phenolphthalein	Par. 19-A Par. 19-A Par. 19-A
Prescriptions: Bismuth, Milk of: Eliminations : Magnesia, Milk of: : Olive Oil: : Phenolphthalein:	Par. 19-A Par. 19-A Par. 19-A Par. 19-A
Psychosomatics: Menopause	Par. 15-A

TEXT OF READING 443-2 F 45

This psychic reading given by Edgar Cayce at his home on Arctic Crescent, Va. Beach, Va., this 16th day of December, 1933.

1. EC: Yes, we have the body here, [443].
2. Now, as we find, while the body may not be said to be in absolutely normal health, or that there may not be conditions that at times disturb the better physical functioning of the body, yet in many respects - when the general physical health and the general physical conditions that surround the body are considered - the body is above the average; while not wholly normal in its reaction.
3. There have been and are periods when varied disturbances arise. These are from some specifics that have disturbed and do disturb the body, but in the main it may be said to be above or beyond the average in its reactions to the varied conditions that arise, and the varied activities for bringing the best in the physical activities of the body.
4. These, then, are conditions as we find them with this body, [443] we are speaking of:

5. In the BLOOD SUPPLY we find there are indications that at times there has existed in the tissue and in various portions of the body the effect of segregations of cellular forces that have BROKEN in the system, forming cysts and other destructive forces to the better physical condition. Yet the applications that have been made have rather PREVENTED reactions to destructive forces, and have brought for the reaction in the nerve, the impulse, the creative influences in the storehouse of energies in the system, that which has produced the absorbent activity.

6. Hence we find at times the body becomes rather nervous, rather reactory to nerve impulses, and may be said to be rather impulsive in its reactions; yet these are as indicated, rather the natural consequences of the changes that take place in the system as related to creating energies for the activity of all the organs and of the nerve and blood stream of the system.

7. In the blood supply of this body (as in most bodies, though it may be illustrated in the activities of the blood stream more thoroughly here than in most physical bodies) lies the life and extenuation of life, the abilities to create and to eliminate from the system destructive forces, as well as within same create constructive, resuscitating, revivifying forces within the body.

8. As to how and through what channels these are carried on becomes, as it were, another story - in the cooperative activity of all the forces of a physical body.

9. As related to the blood stream, there are those divisions in same which must be kept coordinating in their activity as related to the whole association of the organs and the glands of the body. Much in the same way and manner as would the STEAM, in its governing of the approach of the power to the whole organism; or as the carburetor in other forms of impelling forces that may move those things and themselves in the material activity.

10. Hence in the blood supplying forces in this body, when there is kept the proper balance in the diets for the activity in the system, there are the abilities within the influences of the body-mental, the body-physical, to create the proper balance, AIDED through those influences that have made and do make for the accentuation of impulses in the radiation of those forces that GOVERN the flow of this life force through the body; or the governing force in the impulses of the sympathetic and cerebrospinal nerve system.

11. The NERVE SYSTEM becomes involved at times, and there is the tendency occasionally for the injection or the abilities of outside influences - in the form of cold or congestion, or other influences in the field of bacilli as they may become effective upon the active forces in the muco-membranes in various portions of the system, that for the time or for the period affect the body. These, as seen, with the present influences, are usually of short duration in activity; produced by the very abilities in the mental governing forces, through the activity of the imaginative forces in the sympathetic force of the body itself, as well as the impulses for the active forces in the body to create the necessary elements physically to be combative with the detrimental forces, or constructive to that portion of the body necessary to keep a balance within the system itself.

12. As to the influences of external forces that may affect, and do at times affect the activities of the system itself, these are ever present - and are to be meted, and ARE meted out in their relationships to not only cause and effect in a material world but as related to the activities of a mental and spiritual body or mind as related to creative influences WITHIN a physical body - which is as the mental of the spiritual or creative forces, dependent upon the activity of the mental, which is the builder in every influence in any activity of a body, as related to Creative forces and destructive forces. For, truly has it been said, as a man thinketh within his heart or within his blood supply, within the elements and vibrations that are created within the balance of those forces that course through this active force within a body, so IS the response of that body to the creative influence or destructive influence about it. Or, in common parlance, "As a man thinketh in his heart, so is he." Truly may it be said about THIS body, as it thinketh within itself, through those abilities for the creating of the greater principles of influence within this system, aided and abetted truly by those things that are - to the awareness or consciousness of the body - to be met, the application to self of this, that or the other ministrations in the experience, has been found to meet the needs or the emergencies - or extraordinary emergencies - of the physical body in its activity.

13. Then, as to that which may make for the better influences in the physical exercises of the body, in its relationship to physical activity, we would not give other than that which is known within itself; or that there would be an addition to any of the influences within the activity, other than that which is capable of being known by the body in its relationships to the physical being, the mental being, and that which adds to the physical attributes of same.

14. Ready for questions.

15. (Q) Has the cycle of change of life been completed?

(A) It is rather in its last stages of completion. And there will occur those influences necessary for the completion, and the adjusting of the body mentally, physically, if there is held within self the necessary forces for bringing the proper balance and coordination through the periods.

16. (Q) Do you recommend an operation?

(A) Not in the present conditions. For, with the abilities of the body-physical and the body-mental, and with the addition of those influences that are being added to the impulses in the vibrations created in the activity of the hemoglobin in its divisions in the red blood in the plasma or urea itself, in the leukocyte and in that which creates within the ohms its activity in vibration, this would not be necessary. While the applications are rather of the PREVENTATIVE nature than curative forces, they do allow the adjustments within self to so create the balance necessary. While it requires a greater period, it will be much more healthful, hopeful, and effective - than resorting to extreme measures, IN the present condition. Should there arise those emergencies or experiences that would bring about that within the mental influences of the body, as for it to lose its hold upon itself until there was created that which was segregated within the system as to cause destructive forces, THEN there might be a period of consideration in this direction. Not in the present, as we find.

Rather would we increase the rate of the vibrations in the system, that may be aided through the addition of the low form of electrical vibrations that are creative within themselves, to assist in that applied in the present - Radio-Active Appliance in its SIMPLER form; thirty to forty minutes once or twice a day, when the body rests.

And, as indicated from the activities of the body-mental, the body-physical, it should rest DURING the day from physical and mental exertions; and during such a period, whether in the morning, afternoon or evening, or in both, there would be taken with the rest periods those vibrations.

17. (Q) What places are most healthy for this body?

(A) Where there is naturally the greater emanation from the surroundings of creative influences for active forces with the centers of the body itself. Such as may be had in portions of India, or in the Spar [?] [spa - "a resort with mineral springs, from Spa, Belgium, having mineral springs"], or in Virginia Beach, or in California, or in the upper portions of Arizona.

Not that there is the necessity of CHANGING from the present environs or surroundings, for good activity or near normal work; but these places would be more effective. Why? The emanations of the earth in its balance, in the cycle of those influences that girdle the earth in psychic thought, as well as the influences from the earth itself in its ATOMIC vibrations in these particular points.

18. (Q) What are her best hours for work?

(A) Immediately after rest periods. This does not always mean that the rest periods would be the retirement from either physical or mental activity, but rather as tiring self physically and then changing to the mental attitudes - and the point is reached when the apex of these cross in their relationships one to another, in its quieting effect to the body. And after such periods EXCELLENT work may be done, especially that to which the body should lend itself in aiding others - through the records that may be written by the body of the effective activity of vibrations in the material and the mental and spiritual plane, in the effectual activity upon the actions of men and women. Writing!

19. (Q) What cathartics are the least irritating and most effective in promoting better eliminations?

(A) Those that work more effectively with the gastric juices of the duodenum and still at the same time do not create deposits in the colon that are hard to become effective THROUGH - in the activity of the muco-membranes or mucus activity of the muscular forces that produce peristaltic movement. For this body, as we find, it would be better to follow an outline in this manner:

Have periods of one to ten days when small quantities of olive oil would be taken often during the day, a quarter to half a teaspoonful three, four, five, six times a day. Then rest from this, see?

For periods of five to ten days, alternate properties in this manner:
In the evening take a dessertspoonful of Milk of Magnesia in two glasses of water.

The next day take a dessertspoonful of Milk of Bismuth.

The next day take a Phenolphthalein wafer, see? [Phenolax?]

Then rest a day.

Then repeat this, and we will find these will be the effective activities:

The Magnesia tends to make less acidity and a greater activity of the actions through the whole of the jejunum in the body.

The Bismuth will have the tendency to absorb from those portions of the system where poisons have accumulated, that have tended to make for - in times past, when there was the tendency - the accumulations in various portions of cysts, or for adhesions to form in the muco-membranes and intestines, pelvic organs, caecum area, throat, lung, and various portions of the body, and even at times in the epidermis itself. This will tend to draw these (the Bismuth we are speaking of) to the effective activity of spleen, the pancreas, and the ducts of the liver, through the system. Yet in the lower portion would often make for the tendency for LESS peristaltic movement. Hence the periods when the olive oil would be taken.

The Phenolphthalein wafer would be to excite to activity the alkalin reactions in the lacteals of the duodenum and of the liver itself.

These properties are less irritating, and will work better with the principles of the vibrations that are being created by the activities of the blood creation, as well as that which may be created by the Radio-Active forces - that, with the pulsations in various portions, form a completion of the cycle of circulation both to the arterial and venous, in its relation to the hepatic and to the organs of the central portion of the body. Hence these would be the better.

20. (Q) Will the etheronic instrument designed by Dr. Paul Cold, a diagram of which is in my hand, be of value in bettering the health of this body? [Dr. Paul E. Cold, N.D.]

(A) Be of value. While, as given, there is the tendency for the vibrations being active in the present to act in the capacity of the preventative rather than the curative effects, they are more effective because of the temperament of the body - in its ability to act THROUGH and with the creative forces that are built up within self. [See 443-3 on 1/8/34, page 87.] [See 440-3 on 12/18/33 in re similar instrument.]

21. (Q) How can she best develop her psychic ability?

(A) As we would find, through that which may aid in the unfoldment of self as in relation to the creative influences that arise within self; an idea of which may be had through the perusal and application of that which has been given - contemplated and given through these sources - on Meditation. [Paper on Meditation later used in the books A SEARCH FOR GOD I and II]

22. We are through for the present.

REPORTS OF READING 443-2 F 45

R1. 1/8/34 She obtained 443-3 and 443-4, in re health, mental and material affairs.

R2. See the next page for diagram of etheronic instrument for Mrs. [443] re 443-2.

Aetheronic health
Instrument for
Mrs. [443].

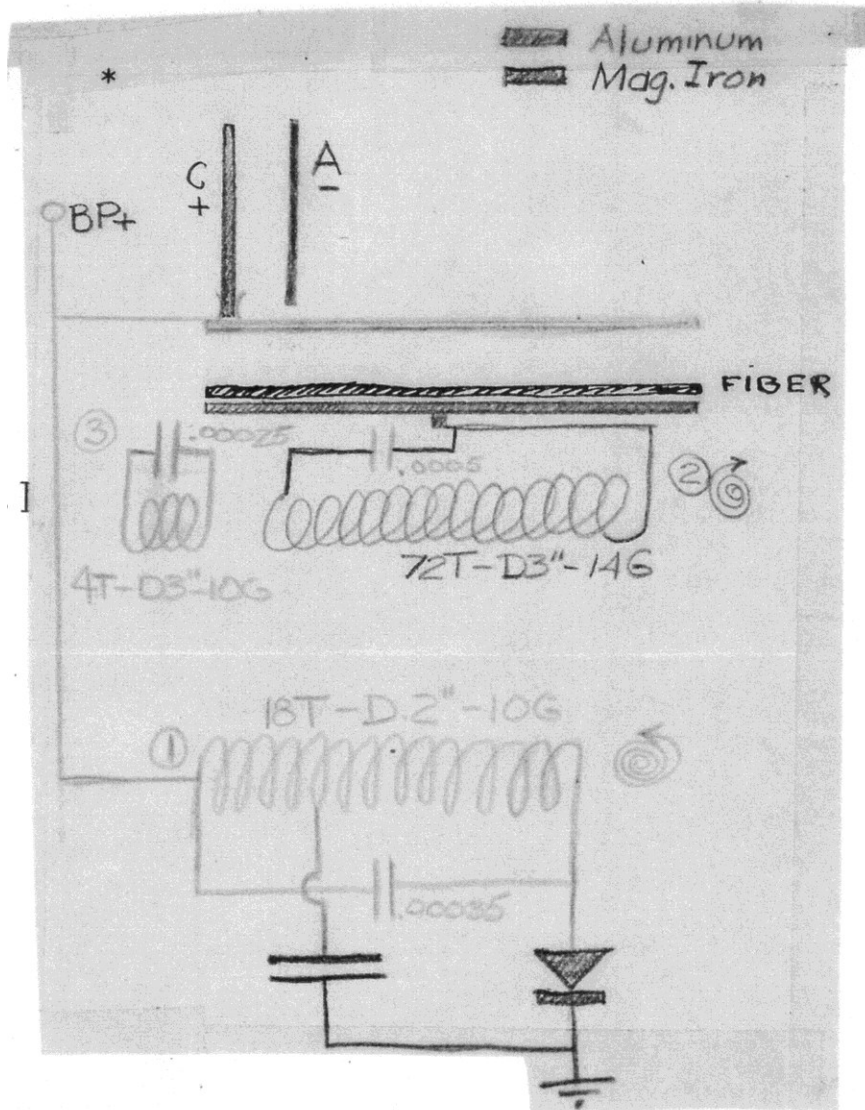

INDEX OF READING 443-3 F 45

[edited]

Angels & Archangels: Halaliel	Par. 22-A
Appliances: Etheronic	Par. 14-A--19-A
Arts: Creative: Writing: Inspirational	Par. 12-A
Healing: Spiritual: General	Par. 13-A
Ideals	Par. 7, 8, 28-A
Meditation: Decisions	Par. 29-A
Numerology: Will	Par. 21-A
Psychic Development: Guidance	Par. 23-A
Psychic Sources: Warnings	Par. 12-A
Reincarnation: Purpose: General	Par. 4
Religion: Oneness	Par. 11-A
Soul Development: Application	Par. 7--9
: Helpfulness: General	Par. 30-A
: Will	Par. 6--8
Soul Retrogression: Desire: Carnal	Par. 7
Spirit Communication	Par. 12-A--27-A
Will: Astrology	Par. 21-A
: Heredity	Par. 21-A
Work: E.C.: Quotations & Similes:	
"First Find Self"	Par. 17-A
"Use What You Have...More Will Be Given"	Par. 18-A
: Readings: Psychic Sources	Par. 22-A

TEXT OF READING 443-3 F 45 (Society Leader, Theosophist Background)

This psychic reading given by Edgar Cayce, this 8th day of January, 1934.

1. GC: You will give a mental and spiritual reading for this entity, giving the original purpose of entrance into this solar realm of experience, trace the mental and spiritual development from the beginning through the various stages of experience and give such guidance as the entity needs in awakening her psychic (soul) faculties and in using same for the higher spiritual development in this life.

2. EC: Yes, we have the entity and the soul and spiritual forces as they have developed in the present and through the experiences in the earth.
3. In giving that which may be helpful in the development of the psychic forces and influences in the present experience of the entity, it will be found that there are those basic influences or forces that have been active or retroactive in the experience of the entity in reaching those conditions in the present experience.
4. In entering the experience in the present, each soul seeks for the manifestations of that which has been its ideal in its reaching those sources from which, to which, the entity, the soul seeks as its associations or companionship.
5. In the present, then, we find from the experiences of the entity in the varied activities of the varied sources of activity brought to the soul, and to the influences in the mind of the soul, the necessity for activity in its relationship to that which had been builded in the experience of the entity from one experience to another.
6. As to the activities of the entity in the present, then, and that which may be the added influence or that through which the psychic or soul forces may make for a greater manifestation in the present - as has been outlined oft, [these activities are] not that which is only conscious of in the experience of a soul or a body but that which the entity, the soul WILLS to do and DOES about that it, the soul or entity, has accepted or does accept as its guiding influence in each experience in its association or contact with those whom that soul or that entity may influence in its actions.
7. Hence, as has been seen in the experiences of the entity in the earth's plane, in the varied surroundings there came the periods when there was a development towards that which had been accepted by the soul or the entity as its ideal, and developments for the entity to or toward that action brought the varied experiences in its relationships to others. Hence those that were in action as in opposition to, or in the varied forms of actions that caused the retarding or the changing of the actions. For, as seen, the mental body, the physical body, with its mental activities, and the soul or spiritual body often war one with another through those two influences that may be designated as will and desire. These are, then, the contending influences in the experiences of every soul, whether these activities are in the direction of that which is held by the soul as its ideal, makes for either that retardment or development in each experience.
8. As to the manifestations in the present for the development of the psychic or soul forces - as the entity applies in its experience that which to the self, to the soul answers for that which makes for the closer relationship, the closer activities in the direction of that held as its ideal, there is made for the ability of influences within self and those from without - of the same nature and character as is being held as the influencing, the impetus, the impulse toward the ideal. Hence to develop, know within self what is being sought from its sources that answer for that which is not only the desire but that is the will of self to bring to the experience those manifestations that are the necessary influences for bringing more and more awareness within self, for the ideals of the soul. How may these be accomplished, then, in self?

9. As an application of an experience is made, it makes way or opens for the next step in the development of the self in that direction - just as the application of the material influences in a physical experience makes for the ability to become aware consciously and unconsciously of the influence making for those forces to DO and to act and to live and to experience that being a portion of the soul itself.

10. Ready for questions.

11. (Q) Which is the highest teaching for this entity, the Christian or the Oriental?

(A) These should be one, for their sources and their emanations - or that they cause or bring in the experience of each soul - are toward the same source.

12. (Q) Should I develop for writing to bring over a book, or trance mediumship?

(A) Develop for writing, as long as self keeps or surrounds self with the influences from without that come only from the higher sources. Or, as self enters into that consciousness where the influences from without are being tempered by that which is desired and willed within the soul of self, there may come that which will be both helpful and beneficial, and constructive in the experience of self for others.

How (is asked) does one know when only the higher influences are active in the impulses, or manner through which such connections or associations are made? Much (in a very crude manner) as when one knows whether the current that may be active in producing vibrations for actions in a material world from electrical forces maintains static as its basis or the force that may bring life or death-dealing forces from its source. By the EFFECT that it produces in those through whom the source or supply comes.

13. (Q) Am I equipped spiritually to do healing?

(A) Each and every soul that seeks and that contacts consciously spiritual forces that are constructive, is a healing force both mentally and (if mentally) physically. Hence the body with its will, with its desire, with its development, may raise those influences within self as to bring healing. By touch. For, as healing is through a physical channel, and as the various activities of body units are raised in their vibration to send out influences to others, there may be seen in self that while all body units are not wholly in unison, but if these are raised properly (which means the will, the desire to be used by Infinity or the God-force in self), it may heal self as well as others. For, in healing others the healing comes to self.

14. (Q) Is the machine that I am using [See 443-2, Par. 20-A on 12/16/33] of value to help others?

(A) Of value to help others.

15. (Q) Will it heal me?

(A) "Will heal me." Raise in self consciously, as the vibrations from machine only aid or add impulse to activities of varied centers in the system, that there is being created that which brings not only to the activity of the body itself but to bring abilities to give out that which is healing to others. And it will bring that sought - and will, desire, kept in accord with the Infinite influence of spiritual force in self.

16. (Q) Should Dr. Cold and I work separately, or together with the instrument?

[Dr. Paul E. Cold, N.D.]

(A) As we find, would be better together.

17. (Q) Is the development I am doing now of the highest, or should I do it alone? [See 443-2, Par. 20-A on 12/16/33.]

(A) As related to the influences for the body-building, is doing in the present. As for that which may be emanated or given out for others, better develop alone. For, as has been given of old, until self finds in self - without the aid save of the Infinite force itself operating in and through self, the reliance is upon other influences rather than the Infinite or God.

18. (Q) Have you instructions for my next step forward?

(A) As there is used that which is known and experienced in self as answering for that which is being sought, the next step is given so long as self is kept selfless, and used as the channel for the Infinite influence through self to that being sought. Hence self may make, may know, may seek better than being given - other than from in or through self.

19. (Q) Can my son [440] be of value with the instrument?

(A) Best that his development be alone or through those influences in self for the present. [See [440]'s subsequent rdgs. in re instrument.]

20. (Q) Is the [psychic] development for my husband [442] also good, or should he not do this work? [See 442-1, Life Rdg. on 11/15/33.]

(A) He should go rather slow, for too impulsive to carry on rather than step by step, line by line. Not bad, if the activity is slow enough. [1/17/34 See husband's rdg. 442-2, Par. 23-A--24-A in re Dr. Paul E. Cold's psychic treatments for Mr. [442].]

21. (Q) Will the astrological forces help his [[442]'s] psychic development at the next change?

(A) They make for an easier channel for the body. As to whether they aid or retard depends upon the desire and the will. For, as given in regard to numbers and astrological influences, environment and impulse from hereditary environs: These may be used - all such influences - or they may be allowed to be over relied upon or over used for destructive forces. But they exist, sure and certain - as does the soul, the mind, the body and the SOURCE from which it emanated!

22. (Q) How high is this source that this information is being given from?

(A) From the universal forces, and as emanated through the teacher that gives same - as one that has been given - Halaliel. [See 262-56, 57]

23. (Q) Has each soul an individual guide?

(A) Each soul has been given, we have given that each soul HAS an individual guide - but the more often does such rise or develop by the choosing. As has been given, "There is set before thee life and death, good and evil - choose thou." But it is just as true, "His angels have been given charge concerning thee." And, as given, [443-1, Par. 39-A] the title for this entity has been written by the entity's development and entity's choosing - the entity not meaning any ONE, but as the experience of the soul and soul-mind through its activities in the various spheres or planes of experience and conscious activity. Here words fail to express the tone, the tenor or the color that each would convey. But that there is the ability within self to contact as high a soul as is sought, by will, by desire, by the use of that attained for THIS soul, for THIS entity to reach into the cosmic or the universal sources for its supply, for its

needs, for its desires. For, with the title clear - as given - that the name is WRITTEN there, and the forces of good, of those that would teach. For in His sphere of activity in the material plane we do not find all teachers, nor all writers. We do not find all gifted alike. Why? From their development. In HIS plane all are not teachers, all are not ministers, all are not healers - but those that have attained with a title that the influences in the universal have, as it were, before them.

28. (Q) How can we find the TRUE ideal?

(A) Only that which answers to that within self can to that soul be the true ideal.

29. (Q) Environment changes, or feelings, so often that it is difficult to distinguish between our environment and our ideal.

(A) This may be to each soul a true answer for that which may be chosen in ANY manner. First seek an answer consciously for any question within thine own environ, thine own surroundings, and let thine own development, thine own ideas, answer yes or no. Then take the answer - yes or no - to the inner consciousness and let thy ruling influence in the Spirit answer. And ye may know, and the truth in same sets you free. For, when one is used by the environs that make for a questioning within self as to its ideal, know the ideal is questioned - even by the better self. Let the answer be in the highest - mental, and then in the spirit itself from within....

REPORTS OF READING 443-3 F 45

R1. 9/23/66 GD's note: [See the book KRISHNAMURTI, by Carlo Soares, 1933, Les Editions Adyar, Paris; also see the many writings of Krishnamurti from 1927 to date.] He broke away from The Theosophical Society in 1927-1929, and the Messianic expectancy around him. 1953-1954 Publishers of his books commented: "He was educated in England from childhood... he followed the path of the Hindu Gurus, although he has arrived at new interpretations...widely known on three continents as a speaker of exceptional clarity and appeal."

R2. 1/8/34 P.M. She obtained her Ck. Physical Rdg. 443-4.

R3. 1/9/34 She obtained 443-5 in re the etheronic instrument.

R4. 1/10/34 See 443-6 in re the instrument and her life and work.

R5. 4/11/34 Her ltr. to HLC: "Between daughter [499]'s engagement and also one I am giving, and trying to get ready to sail for Italy on the 28th, I have had my hands full... Sometime when we are together I would love to tell you how I feel about organizations... I went through Krishnamurti's disbanding of his 150 thousand followers with him. I have also seen many changes in different Theosophical branches... Personally I am convinced that Truth cannot be organized without 'stepping down' truth. The inner development is the only real value, and that is always individual. Your father is too wonderful to have to be surrounded by hero worship. He should be shielded from the blasphemous."

R6. See subsequent rdgs. by her son, Mr. [440], in re Dr. Cold's instrument.

INDEX OF READING 443-4 F 45

[edited]

Appliances: Etheronic	Par. 13-A
Arthritis: General	Par. 12-A
Attitudes & Emotions: Patience	Par. 11-A
Cysts	Par. 8-A
Diet: Appetite: Arthritis	Par. 12-A
Doctors Suggested: Dobbins, Frank P.: D.O.	Par. 13-A
Electrotherapy: Infra-Red Ray: Green Glass: Tumors: Tendencies : Ultra-Violet Light:	Par. 8-A--10-A, 13-A Par. 8-A--10-A
Glands: Thyroid: Hypothyroidism	Par. 7-A
Healing: Oneness	Par. 8-A
Osteopathy: Tumors: Tendencies	Par. 8-A, 9-A, 13-A, 16-A
Physiology & Anatomy: Nervous Systems: Sympathetic	Par. 8-A
Psychosomatics: Healing	Par. 2, 3, 8-A
Spleen: Glands: Thyroid	Par. 7-A
Tumors: Tendencies	Par. 8-A
Work: E.C.: Quotations & Similes: "Like Begets Like"	Par. 3

TEXT OF READING 443-4 F 45

This psychic reading given by Edgar Cayce at his home on Arctic Crescent, Virginia Beach, Va., this 8th day of January, 1934.

2. As we find, there is as yet little or no change materially in the general physical conditions of the body. As given, there lies the ability in the mental forces of the body to meet the greater portion of the emergencies or the general conditions that exist. With the understanding of how that there may be aroused in the functioning of the organs of the body, through the directing of the influences of

the forces in the mental activities of the body, may make for such assimilations as to make for corrections of disorders. That there exists disturbance in varied portions of the system through negative thought or negative reaction to that which may be brought in the body is true, but with the application of those influences that may aid self in making for the balance in the body these may be brought in such a way and manner as to not only produce that which will bring about resuscitating forces but the reviving of the activities where disorders have existed and do exist. As in the digestive system, where there has been the activity in the assimilations of foods through the activity of secretions from the ducts or glands in the liver area, or the gall duct, that has given disorder. By directing through the suggestive forces of the sympathetic mind and activity, or flow of circulation as to RELIEVE the disorder, will create within the lymph circulation such a change in the suggestion and in the activity of the actions in the system as to eradicate, to take from the body that which disturbs same. With same has been the regurgitation in the duodenum, as to cause the reactions as to make for a burning, deep burning sensations through portions of the stomach itself after eating, and the formations of gas in other portions of the digestive system. But all arise from the activities that may be directed by giving the body mental suggestion and seeing, through the abilities of self, the circulation so increased to affected portions as to bring resuscitation to the body. Also where those changes as sought concerning the activity of the organs of the pelvis, where there has been the tendency for accumulations in the tubes themselves, especially in the left portion where this makes for heaviness and the tendency for headaches and accumulations that make for the bearing-down pains at times, necessitating the body resting - for it produces distresses in all portions of the system, affecting directly the nerve forces to head, to the organs of the body in relation to the hepatic elimination. If the body desires to depend upon exterior influences, then there may be given those forces or things that may aid in assisting in elimination, but, as has been given, there may be created within self - from the balance that exists in the mental understanding of the body - that which will aid much better than those applications that may be added to the system as to cause portions of the body and the glands and the functioning organs to come to depend upon other sources of supply than that which is capable of being created within the system itself.

3. What produces that which is capable of growth being carried on in a developing body? What causes or produces that which causes disorder or disease to a body? In the first it is ordinarily given that the impulse from the influences of the amount of atomic force that is given in the influences that bring the active forces into the body, aided and abetted by that which may be taken in and assimilated by the system itself, to reproduce itself and to regenerate its forces from within itself.

Those that produce negative forces that allow the system to become either so degenerate or so inactive in portions of same as to be non-active or non-resistant, but to take on those influences from without in the activity of germ influence or infectious or assimilated influences from contacts with destructive influences in one form or another within the body. But that which has been the

impelling force to create the counter-balance within the body, by raising within self with the addition of necessary vibrations, as indicated, to bring healing to the body itself - and where the body may give out for influences of those natures that may aid others, either by touch or by direct contact, or with sending out through the etheric influences the activities from self - but they must be emanations from health to give health; that is, the reproduction activity. Like begets like. Then, create in self and self's inner self that which will be more constructive, and we may bring for the body a normal health-giving, life-giving, influence in itself.

4. This will also, through the raising of these influences, make for the raising of the pressure in the circulation itself, that makes for a better activity of all gland activity in the body. And all the organs are in themselves glands that depend upon the functioning of that which is created by that assimilated in thought and in diet....

7. (Q) Is there a thyroid condition?

(A) As the activities of the body have been in this mental force, as seen, the thyroids work with the glands of the body and - specifically - with the spleen itself. At times, with the high mental and psychic influences in the body, there is the tendency for the depletion of that secretion from the thyroids, but with the proper balance of circulation through the whole system, by suggested forces or - if it is greater to be desired - the increased vibration in those portions by the addition of outside influences, these may also be given. As is seen, there can be taken those properties internally that will increase same, or materially. But the greater, the better way for keeping and maintaining a balance, is created within self.

8. (Q) Is there a fibroma condition?

(A) In the organs of the body, where there has been the tendency for the accumulations, these may be termed such - if they are drawn on too heavily. But, as we find, they are more of the form of a plethora of the organ to which, and at which, the enlargement shows in the present - and if the circulation is so balanced as to make for - that is, by suggestion, you see - the better conditions of the body, we would not give other than those simple things that may remove or aid in the removing of refuse forces through the eliminating channels of the body. But if there is the increased circulation balanced in the hepatics, so that in the organs of the pelvis where there has been the tendency for this accumulation, these will disappear.

All tissue that has become involved, as cysts in the outer portion of the body, that has existed in one or more portions here - neck, body, and in other portions of same, internally, externally, by the directing of influence or circulation by suggestive influence to the sympathetic forces. For, while we have (this rather an explanation for the whole) the activities of psychic forces which are of the mental, of the soul forces of the influences that direct between the physical body and the soul-mental body, these are active through GLANDS internally.

The expression of these is seen through the activity of the sympathetic nerve system, which is double in its nature, extending from the base of the brain - where it joins in the first cervical the glands - there is direct connection between the cerebro-spinal and the cranium nerve ducts, nerve activities and lobes themselves, and extend throughout the whole of the cerebro-spinal system. And

along each side of same, nerves from the sympathetic join at every specific center the cerebro-spinal in the activity of glands and of organs in varied portions of the body. They extend internally and superficially, or externally, even more to the activity of the sensory organs and to the whole of the sympathetic system, or to the outer portion of the body. Moving then as a greater area from which impulses are received to an active body. That these may be magnified or raised to a greater or lesser degree in varied individuals, depends upon that which may be termed their susceptibility or, properly termed, their DEVELOPMENT mentally, spiritually, SOULLY, in their response to influences that come into their experience. Hence, as given for this body, this body may be termed a very sensitive individual or body, and will respond from feeling (not from the sensory feeling), from sight (not just from the sensory sight but the feeling sight as well), from the auditory forces - that may be heard, not only from that which may be seen by self or about self, but as seen from within and from without. Hence the body may be said to be able to create within self those influences of the greater nature that may bring the more perfect balance in the physical forces of the body. Now, if there is desired (the choice must be made within self), we would give choose to create those influences for self - but if there is desired there may be added to the body outside influences of such a nature that these may be overcome the more readily; for, as has been given, whatever influence is added to a body - whether medicine, applications externally, electrical vibrations, suggestive therapeutics, operative measures or what not the HEALING must come from that which is capable of being created by this body within itself; that is, the association between the spirit of the body and the physical body. But should it desire to apply external forces, we would make corrections osteopathically of the influences in the lower portion of the cerebro-spinal system; namely, from the lower portion of the caecum or sacral area, including the caecum area, and the opposite area in the pelvis region, and those vibrations made by the creating of stimuli to the ganglia in this particular area - and the hypogastric and pneumogastric area, from the 5th dorsal to the base of the brain, and these made coordinately; and the addition of the vibrations from the ultra-violet ray as combined with the Infra Red, if green is used between the red and the body. Thus we will create a greater amount of stimuli in a more specific time (if we count time), but the better is created in self.

9. (Q) Where would I get that ray?

(A) Any real osteopath gives it, see. The ultra-violet and the Infra Red. The Infra Red is for the deeper application, or for the bone or structural portions of the body as related to their activity with assimilations and eliminations, while the ultra-violet works with deeper and the superficial, while the manipulations and adjustments in the specific areas given - the sacral, the lumbar and the abdominal area, especially in the caecum, across the whole of the colon area and down from the ascending, transverse and descending - and with these treatments a stimuli to the plexus that have been stimulated by both manipulation and the activity of the electrical forces, for quicker or greater activity. These may be brought soon to the body, in sixteen to eighteen treatments, should make an entirely different condition in the old feelings in the matter.

If it requires, then, that forty to eighty days be required for it to be done in self - can't you wait that long?

10. (Q) Over what area and when should the lights be applied?

(A) The applications of the Infra Red should be preferably (if these are to be applied) in the brachial plexus area, and their activity will be upon the structural portions of the sternum and the ribs and the spinal area, aiding the lungs and the ribs in the creating of the variation in the blood supply. The ultra violet would be applied to the solar plexus center, or 9th dorsal to the lower portion of the body, see? The Infra Red would be applied from twenty to thirty minutes, at least forty-two inches from the body. The ultra-violet ray would be applied from three to three and a half minutes, thirty-eight inches from the body - or farther if these redden too much, see?

11. (Q) Is the flatulency part of this condition, or fundamental?

(A) It's not fundamental, for - as given, and as we would rather insist - fundamentally this body has within itself not only the abilities, the powers to create or bring about within itself a perfect, normal body, health-giving, health-flowing, but capable of giving off health, life and influence to others. Then, it must be powerful, it must be basically right! What prevents same? Being pulled here, there, or accepting this or not capable or willing to be patient enough even with self. And yet self is considered, or may be said to be more patient with others than with self. This is rather a thing to be desired, yet be patient with self also. Often has been the injunction to those that may do the most: "Stand still and see the glory of the Lord," even in thine own self.

12. (Q) Can I eliminate the arthritis?

(A) Arthritis is ever a result, not a cause; only a condition from lack of the proper balance in elements within the body itself. Does [If the body desires] the body desire - even after it may eliminate these conditions from the body, for it seeks to have it done outside - to create within self that which may bring about the keeping or a perfecting of a balance within self, then begin by knowing first what is the proper relation of all elements in the body, or - as it were - study something of not only the anatomy but the chemistry of the body, and see in self's own visioning - as it visions or hears or feels or sees in its inner self, as it meditates upon it - THAT BEING builded, that being accomplished, that is making and will make this proper balance. This activity of itself will create desires for characterization of food values to be assimilated, and follow those hunches - if you want to call them such - and you won't eat wrong, you will eat right!

13. (Q) Does this [Dr. Paul E. Cold's etheronic] instrument here in this room help to heal these conditions?

(A) It hasn't changed! We have given that it helps! [See 443-2 & 443-3.]

14. That is all the questions regarding this body.

15. We would, then, for this body, follow that outline; at least twice each week take the manipulations and adjustments, thoroughly given, COORDINATING the adjustments and treatments in the lumbar and sacral area WITH the upper dorsal and cervical area. At least ONCE each week, or twice each week, apply the lights as indicated, but - to be sure - do not apply these at the same day, see?

These should be at least twice each week, the Infra Red, using a green light - that is, a green glass, sufficient distance from the Infra Red, see - then we have the effect of both of these. Dobbins can give it, you see.

16. (Q) Should the Milk of Bismuth and Magnesia as suggested before be used?

(A) Apply all these things and then give that too? No, we haven't give it this time. But if you follow the outline, there is to be given specific treatment osteopathically, following from the caecum, the ascending, the transverse and the descending colon, see? Also the manipulation, which is not only on the spine but over the abdomen and over the organs of the abdomen, will produce - with the activities of the electrical vibrations - that which will soon bring about the normal forces.

But we would create in self that which may keep a perfect balance, for this is the more perfect way. We are through with this reading.

REPORTS OF READING 443-4 F 45

R1. 1/8/34 P.M. Immediately following 443-4 see son's rdg. 440-10, Par. 4-A advising against etheronic instrument for him.

R2. 1/9/34 and 1/10/34 See 443-5 and 443-6 in re the etheronic instrument and her life and work....

R4. 4/12/34 Son [440]'s ltr. indicated Mrs. [443] was confused and in doubt about Dr. Paul E. Cold, though "she still admits that the instrument may work."
"...Mother's opinion will suddenly swing again one of these fine days."

R5. 4/25/34 Son [440]'s ltr.: "Mother [443] appears to be very much in doubt about the rdgs. She says that she thinks you were off with her Physical Rdg. as a Dr. in N.Y. has just discovered that all her trouble has been coming from a sinus infection, for by eliminating the infection he has produced a most remarkable cure upon her."

R6. 5/17/34 Dr. Frank P. Dobbins' letter: "Mrs. [443] had two treatments but decided that she had best go to some foreign spa to clear up her streptococcic (?) infection."

INDEX OF READING 443-5 F 45

Akashic Records	Par. 20-A, 37-A, 38-A
APPLIANCES: ETHERONIC	
Healing: General	Par. 9
Names: People Mentioned: See, T.J.J.	Par. 12-A
Rejuvenation: Appliances: Etheronic	Par. 36-A

BACKGROUND OF READING 443-5 F 45

B1. See previous rdgs. in which she sought information concerning Dr. Paul E. Cold's etheronic instrument.

TEXT OF READING 443-5 F 45 (Housewife, Club Woman, Theosophist Background)

This psychic reading given by Edgar Cayce at his home on Arctic Crescent, Virginia Beach, Va., this 9th day of January, 1934.

1. GC: You will have before you the etheronic instrument, present in this room, and the theory behind it; also the enquiring minds of those present in this room in regard to it. You will answer the questions which will be submitted, as I ask them:
2. EC: Yes, we have the instrument here, present in this room, the enquiring minds of those present.
3. As to the theory behind the instrument, we find it is in part correct and partially not as great as even the possibilities the machine offers in its activity or its influence upon individual conditions.
4. The manner of construction of the instrument, as we find, is very good. The theory of the etheronic radiation is very good. The differentiation in the instrument and that which would cause the operation upon individuals, or the individuals operating same, is not wholly in accord with that - as we find - to make for the betterment of conditions of individuals. For, worked from the basis that at present exists, there will be times when the effect upon individuals is not so well as at others. Why? There are times when the individual applying same does not give off or receive for the individual to whom the application may be directed. For in its receptive force, as we find, if there is the correct or the probable MORE correct conditions for reception by individuals in near proximity or no matter how far distance; for the etheronic wave and its activity may be just as active many miles away as close, though - to be sure - if the things CROSS certain influences it becomes deflected. This is sort of confusing, but we will straighten here:

5. As to the variation that we would find in construction, first this as a theory before the construction: That there is ever being thrown off not only by the sun but the planets or even the stars, an influence upon life in the earth - or in any sphere.
6. As we find, the better demonstrations that may be made for the correcting of the vibration would be to plant life. Then corrections may be made for body or physical life.
7. Then, as to the construction here in this machine, as we find, it may be made a real universal value to every individual - as constructed here. In the aerial, then, would we find some change. Where the carbons are in contact with the coil that is to build up a radiation for individual contact, whether present or distant, make or use that which will tend in its elements to draw to - or magnetized metal with glass about the end in which the carbon is placed. As we find, this will increase the efficiency and there will be less retroactive conditions in varied characters of treatments or varied individuals.
8. Hence in this change, as we find, would be the greater portion of that which we would change for the manner or the way of the application of the instrument shown here, for the beneficent effects in individuals.
9. Of course, some individuals in applying the machine itself are more sensitive than others. Others will be found that there are certain characters of disorders, or certain conditions where there will be more ready response. But the theory, if formulated in the activities, will be found to be quite universally effective and beneficially so. But let no individual ever get the idea that any instrument, any application that may ever be made - if it can be beneficial, it can be harmful! Then, in making the sensitive applications to individuals, as the psychic influences of an individual must also be helpful, must be aidful in the operation of or the sending of the influences out to individuals that may be aided by the body.
10. Then, there must be for such a sensitive - and the greater sensitive the less personal is the application and the greater the universality of the individuals' abilities to be aidful to others arises.
11. Ready for questions.
12. (Q) Is the electro-dynamic wave-theory of physical forces, as expounded in the two volumes which I hold in my hand - by T. J. J. See, a truer concept of the natural forces than is now accepted by science?
(A) Yes. This doesn't mean that it is wholly out, but because it is nearer than that now accepted by science. See? But with this very machine here, as we find, with little alterations and with experimentations there may be brought almost the perfect radiation in this activity, or form of activity of treating or aiding individuals.
13. (Q) What is the best method of inducing etheronic energy?
(A) You have it here. Save, as we would find (in this particular instrument) the building up of the influence of those rays that go out from either the influences that may be had in the rays - or later it may be developed that medications may be done the same way, for they have their radiation and their vibration.

14. (Q) Do you find the materials of which the condensers are constructed can be improved?

(A) These are well, as we find them in the present. Some alterations may be found necessary as experimentations progress. Only in the condensing from the outside, or from the aerial to that through which or that which passes through the machine or the vibrations being sent out for same would we alter or change.

15. (Q) Describe the nature of this aerial.

(A) In the reconstruction or in the construction of that we would have layers of a metal that is highly conducive to magnetization, see? In or about this we would have glass, see, encased about same, see, which may be made as in a socket, or which may be made as separate pieces is more effective, but bound together by or with non-conductive influences as is seen here, or bakelite, or there are others that are even more conducive to less activity of conduction, see? In this way and manner we would find that there will be the building up of reception and of sending out that is the concentration of same, see?

16. (Q) Give the dimensions of these parts.

(A) Make them in proportion to the sides. Use some activity in yourself and the experimentation, and you will find that you will gain more than being just shown in each little step and maybe move this and work over that; while in experimentation you would find for yourself as to how or why these would be effective in bringing that which IS being given as the manner in which condensation from the etheronic rays or psychic influences from body to concentration - or aiding in concentration from diffusion of same - of those at a distance.

17. (Q) In earlier reading you suggested that a similar instrument have its crystal constructed from elements.

(A) This is not the same character of instrument, or the inducive into the active forces through the coil. It's not the same. This is better!

18. (Q) Is etheronic energy amenable to mental control?

(A) It IS mental control. [GD's note: See 440-13, 24-A on 1/19/34.]

19. (Q) Can it be used to neutralize conditions in the body?

(A) As conducted or inducted through mechanical forces that are demonstrated here, it can be used. But you will never neutralize WHOLLY without producing the elements of neutralization. To make for the broader field this may be done through the instrument, though as has been illustrated and demonstrated in hypnosis or mesmeric influence, the etheronic fluid passes from one individual to another in making for the allaying or neutralizing of conditions within a body. THIS, then, becomes that which takes from a body in such a way and manner as to eventually destroy the abilities of the body so neutralizing through such activity to create power. Here you have it done mechanically, yet you are taking the influence from the UNIVERSAL forces, or that may be supplied by the influences of radio-active forces from the sun, the moon, the stars, and the individuals themselves.

Hence it will NOT reduce or deduce the conditions in the individual who would act as the medium of direction of such influences created by the gathering of the force to reduce the vitality, but in giving out aid self also.

20. (Q) As given through this channel, we understand the akashic records are recorded on the ether. Then, cannot an instrument be invented to induct ether and thus tap in on the akashic records?

(A) But this would be induction or rolling back, while THIS in this particular instrument here is rolling out - or taking that in the present activity and giving out. But would necessitate rather a varied or different form, but using much of the same theory as is used or shown here in its activity. Yet this may be done - eventually will!

21. (Q) Can you suggest a better method of sensing resonance than rubbing the finger on the bakelite?

(A) No. This creates for the force itself that which is necessary for the sensitizing or the centralizing of the individual for such activity.

22. (Q) What conditions are best treated by this instrument?

(A) Inasmuch as this acts as a neutralization of influences in the system, those that are induced into the system through the blood stream and the nerve system are the ones that may be aided the most. And what have you that isn't? Save where there has become, of course, infectious forces by contact and that is of the contagious nature. Do not attempt very much in this nature, with this type machine, as yet.

23. (Q) When I, [443], tune the left hand dial to the vibration of an individual, is the fundamental or harmonic of that vibration entering the instrument?

(A) Entering the instrument. For, as the position (this might become confusing, but you are using it whether you know it or not), as the instrument is attuned to those influences that are emanations from the body of an individual being treated - see, these are exercised or acted upon by the influence of all forces wherein, to which, the body of that individual in its spirit or soul or physical body HAS been amenable, see? As for instance (this will illustrate it and bring it home closer) in treating or making an application for an individual who has been a sot, or subject to drugs or the like, it will be found that these will be very hard contentions at first, see for it necessitates subduing desire that has been acted upon from purely material influences, yet were this from (the same character of treatment for) a nervous breakdown, even produced by pressure in portions of the system itself, as from stoppage in gall ducts or in the forces that arise from thinning of the walls of the arterial circulation itself, or as to produce high or low blood pressure by the activities of various portions of the system, the attuning to same would be quite different and more susceptible than it would in overcoming denser - which has been indicated by the radiation, etheric radiations in activity.

24. (Q) Am I, [443], sensitive enough to use this instrument in its present form?

(A) Sensitive enough, and capable of being of aid and help to many with the instrument.

25. (Q) Should I operate it for humanity or for my own development?

(A) If it's operated for humanity with the right purpose, it will be for the own development also. Then it's both!

26. (Q) Is the best method of inducing another's vibration by having them write their name and lick same and put it in the small drawer?
- (A) The better induction, of course, would be through a smear - but there may be even a garment or anything that has been in constant contact with the body of such a person being treated, for the sufficient period to cover that which has caused or produced the disorder. A smear would be the better.
27. (Q) A smear with blood?
- (A) That's what a smear is; smear with blood, not others.
28. (Q) Should it be constantly refreshed?
- (A) Not necessary, for the blood will show the change; for it is that living force of the body until it passes from material forces. A smear once made - made by the test of the body itself that is operating the machine, know for self as to how well or how much change is being but this, of course, is by practice or by sensitiveness, as it is being turned on for the individual. For, as has been said, it is operative through the forces that come from the mental body itself and not just the THINGS, but as it reacts to the body.
29. (Q) Interpret the numbers as they are tuned by the right hand dial.
- (A) This is as we gave in portion, or presented in thought without expression, is rather as the days as related to the astrological influences - would be the greater on the right hand.
30. (Q) Does it change from day to day?
- (A) It changes from day to day, as it passes from one influence. An astrological chart will show. Not so much the moon, not so often as it is seen, but as they pass from one of the experiences or one of the spheres to another. The change, of course, is then about twelve times in a year.
31. (Q) What is the significance of the central dial?
- (A) That as to increase the power or the flow inductively and outwardly also.
32. (Q) Are our charts alright for finding the different troubles in the body?
- (A) These may be altered considerably, as we find. While the charts in the present, or the present method of it is very good, when the sensitive individual operates with these - if these are located much in the same manner as of following over the various organs and various portions of the system, though the individuals themselves may be separated by miles the direction of the disorder, or location of the disorder, may be eventually made, see?
33. (Q) What would be the simplest way of tuning in to a specific organ and knowing that your number was right?
- (A) If the individual present, direct. If the individual separated, and you have necessitated the use of both the right and left dial, and the increasing of the volume through the increased volume here in the center portion to one as near perfect in its own manner of living as may be had - but the individual so being tested should be grounded.
34. (Q) How may it be grounded?
- (A) Standing on plates that are grounded to the earth.
35. (Q) Like the plates I have in front of my desk?
- (A) Similar plates, just so they are of very conductive forces that conduct to the radiations from the vibrations.

36. (Q) Is it possible to rejuvenate the body with etheronic energy?

(A) How else may it be done? From what source does growth come? By the induction into the body of the etheronic forces from life, or plant life, or whatever forms that may be brought, and in not over-using those but keeping an even balance. Yes, it may be done, but you are going into very dangerous fields, until you know what you are doing with it!

37. (Q) Can you tell where the instrument for tuning in on the akashic records would differ from the one we have here?

(A) One we have here we are drawing from the influences, or that influences upon an individual activity separated from the whole yet subject to it, see? while the akashic records is that going out or passing out into the records, see? One is going out, the other is coming in.

38. (Q) What alterations would be necessary to produce this change?

(A) Almost a reversal of the forces to draw in, or would be more on the order of necessitating the raising of the influences that are less affected by the earth itself, or reaching into - that's what you're going to find in your strata sphere - reaching into the forces that the records are being made on the ether - in the force that is above or in circle or globes the earth. Then, these raised so they may be turned back to the expressing in manifested form.

39. (Q) Can these be made perceptible to the earth?

(A) To the earth, and may be made pictures of - you can bring it into that far. They are changed, though, from this machine - so we are through for the present.

REPORTS OF READING 443-5 F 45

R1. 1/10/34 She continued her questions in re the instrument - see 443-6.

INDEX OF READING 443-6 F 45

APPLIANCES: ETHERONIC

Attitudes & Emotions: Constructiveness: Healing	Par. 15-A
Beauty: Definition	Par. 15-A
Bible: Books Of: Luke 11: 26	Par. 18-A
: Mark 7: 20	Par. 17-A
: Matthew 12: 45	Par. 18-A
: Matthew 15: 11	Par. 17-A
: I Timothy 5: 8	Par. 18-A
Diet: Meatless	Par. 17-A
: Nutrition	Par. R2
: Spiritual: General	Par. 17-A
Doctors: Cold, Paul E.: N.D.	Par. 1
Ideals	Par. 4-A
Numerology: Sex: General	Par. 8-A, 32-A
Psychic Development: Healing	Par. 10-A
Psychic Sources: Automatic Writing	Par. 32-A

BACKGROUND OF READING 443-6 F 45

B1. See 443-5 on 1/9/34.

TEXT OF READING 443-6 F 45 (Society Leader, Theosophist Background)

This psychic reading given by Edgar Cayce at his home on Arctic Crescent, Virginia Beach, Va., this 10th day of January, 1934.

P R E S E N T

Edgar Cayce; Gertrude Cayce, Conductor; Gladys Davis, Steno. Mrs. [443] and son Mr. [440], L. B. Cayce and Hugh Lynn Cayce.

1. GC: You will have before you the entity known as [443], present in this room, her manifestations in this life and the information which has been given her through this channel. You will answer the questions which she will ask, regarding her development and work with the instrument, present in this room. [Dr. Paul E. Cold's instrument]

3. Ready for questions.

4. (Q) You have told me in my Life Reading [443-1] that I had many impulses. Will you now show me how to so harmonize them that my mind and emotions always work together?

(A) As may be seen by the experience of the entity, while the emotions and the impulses at times vary, this for many an individual - and for this body - is a natural manner of expression; and if the ideal is always kept as the measuring stick, as it may be termed, the developments will come in the natural order of things or experiences.

Hence in harmonizing, only let the impulses and the activities in those impulses be gauged by the ideal, and it will make for harmony in the experience of the entity in its development.

That impulses and desire often make for contending influences will at times become apparent to this body, yet if the ideal is set, if the ideal is held, if the ideal is made the point of harmonizing or measuring or holding to as the gauge, the guide, the rule, these will make for developments in the proper way and manner. That the body-mind or the impulse for activity often becomes, as it were, bubbling over with enthusiasm for the moment and then, while not cooling - yet calls for in self what others may term as a saner, more rational manner of approach - is that for the moment the ideal, in enthusiasm, may be lost sight of. Hence ONLY harmony may come if this is kept first and foremost.

5. (Q) Instruct me how to operate this instrument, so that I may be a benefit to humanity.

(A) In the first there is, as indicated from that given, the necessity to know within self what is to be done or desired to be done respecting self's influence upon the individual, or group, or people's to be aided, see?

Then, in making the contact for aid, the necessary divining - or divining of the reason for the approach, and what's to be accomplished by same - is to be gained in self's own consciousness.

Then, in adding of self in the abilities of self make those connections or vibrations that will aid in neutralizing or revivifying in the activities of the mental and the physical forces of those that the body would aid.

In the mechanical application, this raising within self, this seeing that which is to be accomplished, must harmonize or work with much - as has just been given - as to what would be the ideal condition for the individual as related to its present or existent conditions. And there will be gathered through the forces those sources of activity as to bring that about in the experience of self, as well as those whom the body would aid.

6. (Q) What is the best method of using the dials?

(A) As indicated. The left for the tuning or toning of self. The right as of getting for the individual the correct attunement to self and the instrument's raising. And the center as centralizing or making for the raising of the power to that of carrying the influence to those that are being aided.

Hence the left is self. The right is the body being aided. The center as centralizing or raising the power in activity.

7. (Q) Is "self" me or the one I am treating?

(A) Self IS the individual using the machine.

8. (Q) Has the human body a number system? If so, what is it?

(A) Those fall into the natural sequence of certain influences. As the male, is either from or to those sequences of twenty-three; while the female - the natural sequences of twenty-eight. Or one the perfect whole number, the other the perfect odd number. And in gaining or obtaining for each its relationship to those vibrations of the sex, in their relationships one to another, that either of the direct application of the anodes or plates or from the smear that may be effected by determining that portion to be aided. For, we would set or begin same with these numbers, dependent upon that to be aided, see?

9. (Q) Do I use the same method to accelerate circulation as to quiet it down?

(A) The same method. For, in making for acceleration is to make for the proper vibration of relation in all portions of the system. That which creates any disorder is the incoordinating of one portion of an organism as is its relationships to another. And in the accelerating of the vibrations, either through pulsation or through nerve plexus or radial activity from nerve plexus, is to make the PERFECT activity; and this NEUTRALIZES that which is disordered in its association or connection with that being acted upon or from, see?

This may be as an illustration in making an application for an individual: We have a body that is disturbed by dysentery and the body itself (in making application, the director of the treatment now for the body) - this we will say is female also, see - the vibrations of self - as may be determined by self from day to day by its own application of its own smear (operator) as to its vibration in that period of treatment, see - is set. That's on the left dial. Then the vibration of the individual who is to be applied or treated is set. The twenty-eight on the right dial. Then, as there is the change necessary in making the application to the metals or the conductors or non-conductors that make the awareness to the treater of that which is being set, then the necessary height to which it is to be treated is turned not only on the right dial but as to make for meeting the raised in that on the central dial, see? Hence we would find in nine cases in ten that point to which it would be raised is the directing of the application for the change in the vibration of nerve impulse to the circulation, through the plexus which governs the hepatic circulation through the lacteal ducts, as aided through the activity of the pancreatic reaction to the ducts of the gall bladder itself. The ducts, not the bladder, see, in its activity. This, then, would bring the vibration to between thirty-six and thirty-eight on the right dial, to most individuals, dependent - of course - upon the seriousness of the disorder or the long-standing and the vitality of the body itself at such a period. This is determined by the operator or director at that period of treatment. Self, then, has been harmonized, see, by its own activity in that particular period of application or manifestation, and that necessary to produce harmony for the body being treated is set to make for the radiation of the influences of such a machine that brings what? Those influences active within the body creating a perfect flow to meet the needs of the disorders in the various sections or parts of the body from cosmic or those influences from without.

10. (Q) What length of time should a treatment be?

(A) This will be dependent, of course, upon the individual itself to whom the application is made, but there should be - and will be found to be - much more harmony reached as long as quiet in self may be maintained by the individual being treated. Then this makes for quite a variation. Some individuals may be quiet for two minutes. Others, over two minutes would become nerve racking. Others may be quiet for twenty minutes to an hour of treatment. But these will be governed by the varied experience and the ability of the director or the one making the application, to HOLD the body being treated. Hence why the psychic, or how the psychic influences of some that are treating or operators have a great difference in their abilities to aid fast or hurriedly or immediately.

11. (Q) How can I know where a condition does not warrant the use of the instrument?

(A) By the rap or by the vibration that comes from contact with the individual's inner vibrating self.

12. (Q) How would I know the difference between positive and negative rap when tuning in?

(A) That which would become - Self has already been changed first, see? Alright! That which, then, becomes abhorrent or to self of such violence as to almost unseat self, don't try to work it - you can't! Be well for making the preparations, or in testing first in plant life, as given; for the flow of vibrations here is that which may be seen even with the naked eye, and activities where scab, smut or any infectious forces will make for an easy attunement or applying to physical bodies. Where, as indicated, there are infectious forces from conditions that are of the nature that do not work the more with the impulse and the circulation, or the nerve and blood supply, but as of the advanced stages of cancer, or advanced stages of leprosy, or the advanced stages of even measles or such conditions - but those in their incipency WON'T vibrate the same, see? for these are where cellular forces grown cold or inactive or low vibrations have allowed outside influences, or such bacilli to enter as to become active in itself. When any condition has reached so it's activity within it - self, and draws FROM the body - then it will not work, see?

13. (Q) What number would you tune in for plants?

(A) Twelve on the left and twenty-seven on the right.

14. (Q) Any particular type of plant that would be best?

(A) All those through which the life flows, that are the most numerous - you see. Nettles, or tobacco, or ferns, or cactus - especially. That's why we have told him to take it out west, you see! There's plenty of them that haven't had anything but life even through their thirst for a long time!

15. (Q) What personal preparation will help me to be more sensitized to the patient and instrument?

(A) Very much the manner that has ever been for the initiates or the higher sensitized natures or activity. PURIFY SELF! mentally, physically, and not that these become mere rote - but that as the intuitive influences of self give as necessary for the immediate action at that time. Hence, as given, more readily may it be seen how that in giving out through the use of the Infinite forces in such

an instrument, where there is being called into same - as it were - those influences and forces that make for a radiation or activity of the influences in self's experience, it heals self in healing others. Then, a natural consequence when - as seen; for if self is purified, if self is consecrated to a service of constructive influences, how may any other come into self's own experience? BEAUTIFUL, if followed and kept sincere in the necessary qualifying of self - and especially in that which indicates to self being qualified. Never when anger, resentment, hate or any of the influences have torn - as it were - the emotions of the body, attempt to use such an instrument - or do so to self's undoing.

For, when there is given into the hands of a soul such an influence that may be so effective upon the minds, the souls, the bodies of others, one takes hold on such with - as has been termed - fear and trembling, but fear and trembling in this sense or connection means rather doing so with the freewill of self making the desires and the outcome in accord with the sources of the supply that aids. That's beautiful, if it's kept properly. For, Beauty is a thing, a condition, an experience, being that which it should be.

16. (Q) Does my dieting help or prayer?

(A) Both.

17. (Q) Does meat affect one's spiritual understanding?

(A) If there is that consciousness in self that it is affected. But rather, as the conditions, the experiences, the surroundings of each soul become spiritualized; for "It is not that which goeth into a man that defileth him but that which cometh out."

But to attempt, where the bloodstream - where the body- building forces of the nature's warriors within self have been builded for generations, those that have required the stability or stamina of meat - to relieve self of same entirely is to take from the revivifying influences of that body. For, spirituality by the flesh is as the spiritual life in its essence, a growth.

18. (Q) Can healing be instantaneous or is it always progressive?

(A) The NATURAL bent is progressive, but this does not indicate it may not be instantaneous. For, as the operator progresses in the experience, to be every whit whole in any way, either in self or the one being treated, is to be IMMEDIATELY healed. But, as has been always - and ever shall be, the progress, or the maintaining of that attained is through growth. For, to be healed immediately and then be separated and gradually lose self - how has it been given as of old? He that looketh, and he that has gained the concept of the spirit of the influences in the Infinity and turns back - the last estate of that man is worse than the first!

So, as each individual and each operator that sets about to use those influences, when you have once put your hands to the plow and then turn back - "He that looketh back is worse than the infidel."

19. (Q) Is copper the best positive conductor of etheronic and aluminum the best negative conductor?

(A) Copper is the best positive, but nickel is the better negative of etheronic conductor. For, as seen by the experimentations that have been seen in aluminum, that which comprises its elements - in the act of etheronic influence

upon - is to make for a tendency for disintegration that is not the better; while in nickel it comprises such influences that these would become better elements in the etheronic control.

20. (Q) Would it be better to have wound the aluminum coils with nickel wire?

(A) They are the better.

21. (Q) When center dial is tuned to zero are forces entering and being radiated at a minimum or maximum?

(A) At a minimum.

22. (Q) Do we understand correctly that right hand dial as described in previous information refers to the one on the right of the one facing and operating the machine?

(A) On the right of one facing and operating machine.

23. (Q) Give a detailed description of how the right hand dial should be used in relation to astrological conditions?

(A) As indicated, when there is being determined from the smear of the operator - or from the operator - for the period - there is gained for self that vibration necessary for the astrological influences at that time. This, then, has been given - see?

24. (Q) How many layers of permalloy be used in suggested connection with aerial and machine?

(A) Sufficient to make the proper connections with the metals or glass, dependent (that is to be encased around, see?) - dependent, then, as to how many layers as to how large or the manner in which these in their various forms are set, see, in between.

25. (Q) Should the layers be separated by layers of bakelite?

(A) Would be more efficient.

26. (Q) What should be the dimensions of these layers?

(A) As just given before. Would we vibrate with these again? How are the various forms to form the surrounding that is to build up that concentrated of the influence? These would be in accordance with just how large, just how long, or just what is necessary to complete the circle for the socket in which it is to be set, see? Whether it's to be large enough so it would be something like two inches in diameter or as to whether the size of the carbon and the manner in which it is to be inserted is to fit to the smaller size. Then, these may be made uniform - or may be made to fit the various necessities.

27. (Q) Should the carbon touch just the top layer or go through the layers?

(A) If inserted so it touches the second layer, would be the more preferable way and manner.

28. (Q) How large should the carbon aerial be?

(A) The longer the more preferable in ordinary circumstance; not so that it becomes inconvenient, see? In diameter that to the half is sufficient, or even smaller if better to be - or easier to be obtained.

29. (Q) What shape? Should it be fan-shaped?

(A) Not necessarily a fan-shape. It may be only the point, or points, see?

30. (Q) How does the polarization of the permaloy affect the operation of the instrument?

(A) The polarization should always be that as the polarization to the circuit at the time of the application. That is, there is not the true north and south at the various periods of their movement of the earth through its course about the sun, but the TRUE polarization - or true east-west, true north-south, should be maintained in its operation, see? Hence the sitter, or the one using the machine, would be facing - FACING the true east. We most look for all from the east, yes.

31. (Q) Would the north pole of the permaloy be adjacent to true south pole?

(A) To true south pole.

32. (Q) Information received through [Mr. [317] via automatic writing] - last night indicated that the following system of numbers on the right hand dial should be applied to the body - 1 to 25 head and mind, 25 to 49 thorax; 50 to 74 abdomen; 75 to 100 limbs. Is this correct?

(A) At times it will be correct and at times it will be very far wrong! The application of the numbers, or in reaching - as is seen, or as given, there is the variation between the sex numbers. The male, the twenty-three. The female, twenty-eight. As to what the varied points to make for application will be reached between the dialing of self, or the operator, for its own better vibrations at the time, see? Then, as to the various numbers for the various portions of the body to be affected, will be reached by making or finding that necessary for the individual at its own particular period. To set as a varied or as certain numbers for certain portions is to say that the same thing is always the matter with the thorax or the body or the feet! Is that true? In the action then of the necessary vibrations, these will vary according to that which has been changed - or that which must be neutralized that has produced the variations.

33. We are through for the present.

REPORTS OF READING 443-6 F 45

R1. See subsequent notations under 443-1 and 443-3 Reports.

R2. See Source File Key #443 for Vegetarian Times, April 1996, article based on Ann Louise Gittleman's new book *Your Body Knows Best* re 443-6. See 443-6 Text, Par. 17.

INDEX OF READING 490-1 M 42

[edited]

Akashic Records	Par. 12, 13
Appliances: Psychonograph	Par. 30-A--32-A, 34-A, R3
Astrology: Ineffectual	Par. 2--5
: Jupiter	Par. 7
: Mercury	Par. 8
Attitudes & Emotions: Joy	Par. 26
Bible: Books Of: Luke 9: 25	Par. 18, 31-A
: Mark 8: 36	Par. 18, 31-A
: Matthew 16: 26	Par. 18, 31-A
Ideals: Service	Par. 24, 26
Incarnations: Egypt: Ra Ta	Par. 19--21
: France	Par. 15--18
: Mongolia	Par. 22
: Italy	Par. 16--18
Names: People Mentioned: Da Vinci, Leonardo	Par. 16, 17
: Fulton, Robert	Par. 15
Soul Development: Application	Par. 6, 12
Soul Retrogression: Desire: Carnal	Par. 21, 24
Vocational Guidance: Healing	Par. 25

BACKGROUND OF READING 490-1 M 42

None.

TEXT OF READING 490-1 M 42 (Naturopath)

This psychic reading given by Edgar Cayce at the home of Mr. and Mrs. T. Mitchell Hastings, 410 Park Avenue, New York City, this 18th day of January, 1934, in accordance with request made by self - Dr. [490], new Associate Member of the Ass'n for Research & Enlightenment, Inc., recommended by [440].

P R E S E N T

Edgar Cayce; Hugh Lynn Cayce, Conductor; Gladys Davis, Steno. [490], [443] and [440].

(Life Reading Suggestion)

8. Hence we find one of a high mental ability through the Mercurian sojourn. We find one of rather a temperamental atmosphere about self at times, somewhat moody at others, and at others rather buoyant under WHATEVER may be the activity. And when others have lost hope, oft does the entity through this very sojourn determine to carry on, especially if that as related to the surrounding is the ideal of the entity or soul with its entity's activity.

9. One also we find that will not only meet or be associated with a great number of individuals and personalities, but will have - with the application of the mental abilities of the entity in the present sojourn - much to do with the thought or the mental application or stimuli to the physical and mental application of individuals in their experience in this sojourn. These through those influences from the Jupiterian sojourn or activity. These have made for the greater influence in the entity, for the entity - being what may be termed by some as determined and hard-headed - is a very sensitive soul; one that is attuned to much that might escape the notice of others in any field of activity, whether it is gaining the concept of the beauty of a sunset, the harmony in a musical rendition, or whether in the moods of individuals or the activities as related to the relationships between the varied kingdoms in their activity in a material plane. Hence we may find in the application of the abilities in the present, the entity will come to those places where decisions must be made, not only that will deal with those conditions that will be the experiences in the present sojourn of self but as to what will be the experiences or opportunities of many another soul.

10. Hence much may be said to rest upon the entity in its activities during the present sojourn, from the abilities, possibilities, and the activity that makes for ABILITY in these directions.

11. We also find that while these are the influences from sojourns, it may be said that things INTEREST the entity - or conditions with things; but more particularly do things in their activity create or influence or furnish a stimuli for thought and activity of individuals. Hence humanity, or the ACTIVITY of humanity as a whole - rather than humanity as individual - is of greater interest to the entity in ITS activity.

12. How, it may be asked, do you arrive at such conclusions from the entity's sojourn in those environs as indicated? By what the entity did in those environs with the abilities or knowledge that the entity had in its soul development during such a sojourn. From what, then, do you gather such information? Where are the records kept? Upon what are they recorded? Upon the etheric wave in time and space. What IS the film that makes between time and space? That's what you are looking for, [490]! You'll find it!

13. This film - in this film is the difference between the movement OF the atomic force about its center and the impression that is made UPON those passing BETWEEN light and heat, not darkness, for darkness may not exist where light has found its way. Though you may not be conscious or aware of its existence, its rays from the very records of time and space turn their emanations to give to a finite mind the dimensions themselves.

14. As to the application of self respecting the influences upon the entity in its sojourns in the earth, we find:

15. Before this the entity was among those peoples to whom the inventor of the steam's application to the motor, or in France, to whom Fulton went - in the name Eben Claire [?], and the entity was among those that were in this household to whom the entity or body Fulton came; and the entity aided in the material surroundings, but during the sojourn in that experience applied self in attempting to determine ways and means and manners to carry out the ideas that were gathered by the entity Eben in its association with that body Fulton during its sojourn in that experience. Little has been heard, little has been gathered of the entity's activities in that sojourn along the Seine, yet much in the soul development, much in the abilities of the entity in the present in DETERMINATION arises from the experiences in that particular period.

16. Before this we find the entity was in quite a different, yet quite a close character of development; for he was during those periods when the great artist, the great musician, the great scientist was attempting to make the first experiments with lighter than air machines, or painting the pictures that have become as the mystery of the smile of that particular one.

17. The entity then, in the name Guiraleldio, was that one who aided Da Vinci when much experimentation was made, and much that has been accredited to the scientist Da Vinci in the experimentations made may rather have been accredited to this entity during that sojourn.

18. The entity lost and gained in the experience, for - losing confidence in the correct understandings or relations that were existing in the entity's environs in that experience - the entity wasted much of its ability in riotous living association; yet the abilities, the activities in the inner self, if they are kept with an ideal in the foreground - that is rather of the spiritual than of the material, kept AS that guiding star, that guiding home; for EVER should the entity remember, though ye gain the whole world and lose thine own soul it is nothing.

19. Before this we find the entity was in that land now known as the Egyptian, during those periods when there were the sojournings from the Atlantean land.

20. The entity then was among the peoples that were of ONE in Atlantis, that journeyed to Egypt and aided in those establishments of the experimentations that dealt with the principles of plant AND animal, rather than mineral, as to the applications of these principles to the curative forces in human ills; and may be said to have been upon the staff of the hospitalizations that were established during that building up in that period.

21. The entity gained and lost, gained and lost, from its own soul development, while much of the material, of the world, those of carnal forces that go to make up carnal pleasures, came into the experience of the entity to USE. Yet the USE of same, AS used, brought much of disturbing forces to the entity. While the abilities in the gathering of data, or experimental data in the application of much as may be termed as drugs in the present, were used in such work by the entity, and while to the world the entity meant much - to SELF the development was not beyond reproach.

22. Before this we find the entity was in that land now known as the desert lands in the Mongoloid, in those periods when there were the highest of the developments in that particular land; for with the rise of the civilizations or

activities in other lands, the disintegration began there. Yet the entity in ITS sojourn was among the rulers of the land that gathered not only tenets as of daily thought, but much of that which might be applied to the physical and moral life of the individual, of the group, of the home, in that particular experience; in the name Ichexo - as would be translated in this expression, but not the sound from there, for the name as sounded would be Isheckel [?].

23. As to the abilities of the entity in the present, and that to which it may attain, and how:

24. As has been indicated from the experiences of the entity in its material development, some experiences have been wasted. In its soul and spiritual applications in other environs, soul development - but tried ever so as by fire has been, and will be, the experience - until the entity is able to conquer in self that of keeping the purposes, the aims, the desires of the body, of the mind, of the soul, NAUGHT in self save as to its service it may give to its fellow man.

25. In those fields of activity, then, in which there may be applied that which may be beneficial to man in his approach to the preparation of his thinking, of his physical being, for the development of his body, of his mind, that the spirit and the soul that worketh in and through same in manifested form in a material world may have the better channel to serve in.

26. Keep the heart, the mind, joyous in a service that may bring to self, to others, the greater understanding as to what life's expression in and through matter is all about.

27. Ready for questions.

28. (Q) What was the "work" that I was to do that the "Voice" told me in Key West?

(A) To keep in line that shown thee in the mount. The mount - that in the meditation in the spiritual things.

29. (Q) Am I doing this work now?

(A) Excellent!

30. (Q) Why was the Psychonograph given me? [GD's note: See [440] series re experiments with this machine.]

(A) That there may be the testing in self as to the aims, the desires, the purposes in the inner self; for it will mean much to many men, to many peoples, in finding themselves through the cleansing of the impurities in their physical being.

31. (Q) Should I do "public" work with it, lecturing, etc., or use it in a sanitarium, or use it in a private office?

(A) In its perfected form, as is seen to be in the keeping, the greater number may be reached by going to those and lecturing and showing how others may use and apply it in their associations, but with same comes those responsibilities that must be shouldered - that would be beyond that of using it in any one place. It is WORTHY of being given to many. Then give it, and shoulder the responsibility, but know that - as has been given - to gain the process, or to gain the laudation even of thine fellow man, and to lose thine own association, is as NAUGHT.

32. (Q) Should I confine myself to the psychological or the physical work with it?

(A) They MUST include both, to be sure, but the greater press or stress - naturally - must be made in going to others on the physical - but the necessity of the psychological, and of the SPIRITUAL, that must come with it, in its use, may be given. See?

33. (Q) Should I go to Florida to do the work? If not, where?

(A) The surroundings, the conditions there, to be sure, lend that for the greater experimentations in the perfected apparatus, but in its development - the present environs or surroundings would be better for the development or FOR the experimentations, see?

34. (Q) Should it be used in sanitarium work? I do not understand.

(A) May be used in sanitarium work, but the BODY - [490] should TAKE same to others, see, and not confine self ALONE to sanitarium work. Lecture on same! Present same, for it has its place! Do that!

35. We are through for the present.

REPORTS OF READING 490-1 M 42

R1. 1/26/34 [490]'s wife, [500], obtained Life Reading, 500-1. See Par. 26-A in 500-1 re her home relations with [490].

R2. 9/4/43 [490]'s letter to EC: "...I know you will be surprised to hear from me again after a number of years, but I assure you that I have never forgotten our interesting experiences at Mrs. Hastings' and the 'reading' you gave me..."

R3. 9/23/43 [490]'s letter to EC: "...I was indeed glad to get your letter and also the booklet. Reading it over refreshed my memories of the pleasant and instructive times we had together in New York. My experiences while there were unusual and wonderful as I seemed to be so much 'in tune' with the spiritual forces, and received such revelations re the 'Psychonograph' and your readings - the condenser it gave increased the power of Broadcasting and I had some interesting experiences TREATING PATIENTS AT A DISTANCE. When I returned to Florida in 1935 I was full of enthusiasm for the work with the Psychonograph, and with the cooperation of the newspapers had considerable publicity, as I gave lectures each week, demonstrations of the Human Aura, etc. For a while it went over, but finally a reaction set in, as the word spread that 'That Doctor can see right thru you', 'see' your past, etc. So clients began to fall off, so gradually I returned to the regular physical treatments, and meantime, I married [...] - [GD's note: Not [500]] and had a baby boy - born March 31, 1937, [...] Jr...

"The circumstances of his prenatal and birth periods being so unusual I feel that he has 'come' for some special purpose and as soon as possible I want a Life Reading for him.

"My experiences after returning to Florida have followed a strange pattern, and naturally I wonder if I am doing 'the Work' as outlined in the reading you gave me, or if I have gone off on a by-path..."

INDEX OF READING 267-2 F 38

[edited]

ANEMIA

Appliances: Etheronic	Par. 23-A, 24-A
Body: Mental	Par. 26-A
: Physical	Par. 26-A
Diet: Anemia	Par. 15
Doctors: Cold, Paul E.: N.D.	Par. 23-A, 24-A
Doctors Suggested: Crews, Gena Lowndes: D.O.	Par. 20-A, 22-A
Electrotherapy: Respirator: Circulation: Incoordination	Par. 8, 12, 14, 20-A, 22-A
Headache: Spine: Subluxations	Par. 20-A
Nervous Systems: Shock	Par. 3, 5, 22-A
Osteopathy: Spine: Subluxations	Par. 12, 20-A, 22-A
Pelvic Disorders: Menoxenia	Par. 25-A
Physiology & Anatomy: Circulation: Lymph	Par. 22-A
Psychic Development: Healing	Par. 26-A
: Warnings	Par. 26-A
Soul: Body	Par. 26-A
SPINE: SUBLUXATIONS	
Stomach: Dropped	Par. 10, 16
Supports: Abdominal: Stomach: Dropped	Par. 16
Tumors: Tendencies	Par. 21-A

Background OF READING 267-2 F ADULT

B1. 2/10/33 She obtained Life Reading 267-1. See subsequent reports.

B2. 3/30/34 Mr. [440] requested a Physical Reading for Mrs. [267], with her permission, saying he would finance whatever treatments were involved.

TEXT OF READING 267-2 F 38

This psychic reading given by Edgar Cayce at his home on Arctic Crescent, Virginia Beach, Va., this 6th day of April, 1934.

1. EC: Yes, we have the body here, [267]. Now, as we find, while the body in many respects is very good in the physical reactions, and many conditions are only unbalanced from general tendencies in their reactions, there are disturbing factors and forces that make for periods and conditions that in the activity in the various portions of system do not bring their proper correlations between other functioning organs.
2. Hence these conditions or effects are produced: At times dull headaches; periods of mental repressions, as it were; inability to coordinate the thoughts or activities of the body-physical with the mind and mental forces; at other periods the incapacity of digesting foods that are taken; at others we find the reaction as of heaviness, bearing down - as it were - in the pelvic organs or pelvic regions, heaviness through the lower limbs; the feet seem heavy or draggy; and at other periods the reactions are very, very good.
3. These conditions, as we find, arise from many minor causes. And if there will be the proper corrections, the proper correlation with the respiratory system, with the proper adjustments and alignments from nervous shocks the body has received in its structural portions, with conditions to make for the balance in the digestive and assimilating system to make for proper coordination, we will find the reactions will be such as to bring the much nearer and the more normal forces in the body.
4. The BLOOD SUPPLY shows a malnutrition, rather from the inability of the digestive system to make - as it were - the proper distribution of used energies or forces in the system, as well as lack of the red blood supply in the coagulative forces that arise from the bone structures wherein the activity of the plasm of the blood supply itself, with the activities of the spleen, makes the proper distribution in the system.
5. The structural forces of the body that have received the shocks to the system are in the lower lumbar area, in the central portion of the cerebrospinal system, or 8th and 9th dorsal area, as well as - naturally - those reactions that make for unbalancing the cervical area, through the hypogastric and pneumogastric reactions. These, as indicated, are both sympathetic and reactory conditions.
6. As to the NERVE forces of the body, these we find often are disturbed by the general conditions in the system, as well as the abilities of the mental reaction to make for visioning of forces within the active forces of self. Yet these are controlled often through the sheer WILL of the body. But it produces with same a contraction in the muscular forces in shoulders, in face, in body itself, and especially across the area of the solar plexus centers at times a real heaviness that becomes distressing to the body. These are, then, both physical and reactory.
7. As to the ORGANS of the body themselves, as indicated, these are very good in most of their reactions; for brain forces and the activities of coordination in the cerebrospinal and sensory nerve forces are very good, save as from those periods of reaction through the system that produce these distresses.

8. The respiratory system does not function as deep as it should. Hence those activities with corrections where there would be the use of the pulmonary reaction, or the respirator, would be the more effective to produce a clarification of the supply of already blood forces, and those periods when reaction would make for a cleansing and purifying of the body for the CONSTRUCTIVE influences in the blood forces of the body.

9. As to the heart's action, there are times when there is seemingly a skip-beat. This is rather the affect of the nerve condition, not an organic condition.

10. There is the tendency of the stomach itself to be small, and droopy. This makes for pressures that oftentimes cause the feeling as of a heaviness in the pit of the stomach, and in the activity of the heart and respiratory system; and when there has been the long standing on feet, or when there has been the overactivity of mental forces, the desire for food flies away - as it were - as if there is no need for same; yet these are necessary elements and forces for the body, in proper position.

11. As to the organs of the pelvis and the activity in same, there are distresses by pressures that exist there through the unalignment or the sublaxations in the lumbar and sacral area of the body. These with corrections will bring, as we find, the better reaction to the body.

12. Then, in making the corrections, as we would find that would be the better, we would have periods of treatment through osteopathic manipulations, with adjustments all along the whole of the spine, and the use of the respirator with each treatment - that there may be the proper coordination and balance brought to the upper portion of the body as with the corrective measures made for the lower portions of the body, or through the pelvis and through the lumbar, sacral and lower dorsal area, as well as - naturally - coordinating, in such treatments, the upper portion. Preferably, for this body, these treatments should be about three times each week for the first two weeks; then rest a week; then begin over again.

13. And during such periods be mindful of these conditions:

14. The diet, and the activity of the eliminations through the system. For, we have a very poor reaction nominally in the respiratory system; that is, the sweat glands - with the activity of the lungs' pulsation, or the lungs' activity through the pulsation, with the heart's coordination - do not, as would be termed in mechanics, TIME properly one with another. Hence we have periods of a clammy condition in various portions externally of the body; cold feet, cold hands. At times one might be cold and the other warm; one foot cold and the other warm; one part of the head might be cold and another warm; yet such might be reversed even the very next day. The circulation is not timed, as it were, with the rest of the portions of the system.

15. As to the diet, be mindful (as the body is a very good dietician) that it is well balanced for BLOOD and NERVE building; plenty of meat JUICES, but not so much of the meat. Plenty of celery, radish, carrots, spinach, and all those things that make for blood and nerve forces. Raw cabbage, red cabbage. Not so many potatoes, for these are not so well for the body. Beans, peas; all of these should form a portion of the body's diet; as well as pears and grapes, particularly.

16. Also, after the first treatment, we would use a support for the stomach itself; PREFERABLY a circle or girdle made, from the regular cloth that would be used to bind very tight (not taped) just below the stomach itself, see?

17. Be mindful also that the eliminations through the alimentary canal are kept near normal.

18. And these, as we find, is two to three months, will make for a normal body.

19. Ready for questions.

20. (Q) Is there a separate reason for the headache in the back of my head and the one in the center of the forehead?

(A) This is because of the pressure indicated through the hypogastric and through the reactions from the lower portion of the body, that do not coordinate. These are separate reasons, yes - but the correction of the conditions will eliminate both; for we MUST produce coordination.

As we would find, the better manipulations for this particular case and with the pulmonary instrument - would be through Crews.

21. (Q) Is the diagnosed growth still there? If so, what should be done about it?

(A) When there are kept the balancings, and the accumulations of the whole system are kept properly drained, don't worry about this.

22. (Q) What is the condition of the lymphatics?

(A) From any condition where there is anemia produced, as we have indicated here, either by nerve shock or from the lack of sustaining forces in the system, the lymph is low. Hence the respiratory system should be considered, and the reactions from the use of such a respirator would be the best - and the instrument used by Crews is the only one you'll find anywhere near here, in this vicinity.

23. (Q) Has the Di-Hydranol been of help?

(A) Not particularly; but it hasn't been much harm. That is, it has at times aided; it has at others not been so well. Because there must be produced a coordination before ANY factors can be said to be wholly helpful.

The coordinations from the etheronic energies have been the more helpful vibrations for the body.

24. (Q) Has the etheronic instrument been of help? [Dr. Paul Cold's instrument]

(A) Just as indicated.

25. (Q) Why the irregular menstruation?

(A) This is both from the lack of blood supply and lack of coordination. Naturally this becomes scant and irregular, when there is the pressure from the stomach as indicated from its prolapsus on the pelvic areas and the glands that should make for the normal eliminations, and the incoordinations we have indicated that affect both the white AND red blood supply and the lymph circulation. Do these as we have outlined and we will bring much bettered conditions for this body.

26. (Q) Should the trance work be continued? [See 267-1, Par. R18]

(A) Be better were the physical forces improved before there is too great a strain on the general physical body. To be sure, the activities of the psychic forces and influences about the body are to aid in every way and manner. This condition here should convince the most skeptical that we have a soul body, a

mental body, a physical body - each working and functioning in its own realm; all dependent one upon another, to be sure - but are separate.

27. We are through for the present.

Report OF READING 267-2 F 38

R1. 5/10/34 She reported: "Osteopathic treatments make me feel worse, but Dr. Crews [Gena L. Crews, D.O.] says that's a good sign. I am improving and gaining in weight."

R2. 5/25/34 She obtained Life Rdg. 559-7 for her little daughter.

R3. See subsequent notations under her Life Rdg. 267-1 Reports, indicating that in Nov. 1949 she suffered a stroke and became paralyzed on one side, affecting her speech, etc...

R4. 4/10/59 Friend Miss [369] reported: "Mrs. [267] is amazing in that she has continued her art work using her left hand."

INDEX OF READING 294-167 M 56

[Edgar Cayce]

APPLIANCES: RADIONIC

BACKGROUND OF READING 294-167 M 56

B1. 1/6/34 EC obtained 294-166 for spots on lungs [incipient T.B.?], severe cough and chest pain.

B2. 1/21/34 He sought further advice, in re use of radionic machine [Cold's etheronic machine].

TEXT OF READING 294-167 M 56

This psychic reading given by Edgar Cayce at the home of Mr. and Mrs. Ernest W. Zentgraf, 400 St. Paul's Avenue, Stapleton, Staten Island, N.Y., this 21st day of January, 1934, in accordance with request made by self and Mr. [440].

P R E S E N T

Edgar Cayce; Hugh Lynn Cayce, Conductor; Gladys Davis, Steno. Adolphine, Anita, Eleanor and Adolph Ostwald; Helene, Ernest, Robert, Margret and Lilian Zentgraf; Dr. Frank Dobbins and [440].

1. (Q) HLC: You will tell me at this time if it would be well to attune the body Edgar Cayce to the machine being operated by [440], present in this room.

[Cold's etheronic machine? Radionic?]

(A) EC: Very good.

2. (Q) Is this machine constructed now correctly for treatment for this body?

(A) For anybody!

3. (Q) How long a treatment should be given this body while in this condition?

(A) Three to five minutes.

4. (Q) Is it now set properly for this body?

(A) Set properly.

5. (Q) Should the field of the core in the coil in this instrument reinforce the magnetic field of the earth, or oppose it, as it does in this instrument now?

(A) It should work WITH the field.

6. (Q) Will this hinder this treatment, the way it is now?

(A) No. Has to just go out and come around on the other side.

REPORTS OF READING 294-167 M 56

R1. 1/22/34 EC gave further advice for himself in 294-168 [not included here, no mention of the radionics machine].

INDEX OF READING 967-1 F 42

Appliances: Radionic	Par. 40-A
Attitudes & Emotions: Haste	Par. 36-A
Color Therapy	Par. 40-A
Ideals: Service	Par. 36-A
Spirit Communication	Par. 41-A
Vocational Guidance: Writing	Par. 24, 25, 30, 32

TEXT OF READING 967-1 F 42 (Housewife, Secretary)

This psychic reading given by Edgar Cayce, this 2nd day of August, 1935.

31. As to the abilities in the present, then, and that to which the entity may attain:

32. As a writer, as an editor, as a critic in those things pertaining to writing, to etiquette, to the analysis of the promptings or motivative forces in the experiences of individuals, editing the writings of others.

33. DEVELOP that sensitiveness to color and tone.

34. Ready for questions.

35. (Q) Have I chosen my proper work in life?

(A) As it may be accorded more and more with those inclinations that arise from the associations and experiences we have indicated, yes.

36. (Q) How can I speed up results in the work?

(A) The results as attained, the service as rendered, must be that to enable the entity to make haste slowly. Do not get ahead of the GOOD that is rendered, else we will find the same confusions arising off.

37. (Q) What was my paternal grandparent's name?

(A) As has been indicated, in that association. Great grandparent.

38. (Q) What line and where can it be traced?

(A) As indicated.

39. (Q) Were they the Natural healers and bone-setters?

(A) Natural.

40. (Q) If so, could I do magnetic healing?

(A) Not shown so much in its developments, as indicated, as the training in the sensitiveness to tone and color. Through these vibrations may the entity in its healing and in its efforts bring greater harmony in the experience of others.

Using same with the low electrical forces that make for the using of the etheronic energies may be the greater channel.

41. (Q) Has my father [...] communicated with me?

(A) This should be answered by self. He has. We are through for the present.

INDEX OF READING 1397-1 F 58 [edited]

Appliances: Radionic	Par. 74-A, 75-A, 78-A, R6
Astrology: Jupiter	Par. 17, 18
: Mars	Par. 19--21
: Mercury	Par. 19--21
Attitudes & Emotions: Earth Sojourns	Par. 2
Healing: Magnetic	Par. 73-A, 74-A
Human Relations	Par. 61, 62
Ideals: Belief	Par. 59
Jesus: Grace: Law of	Par. 13, 43
Karma: General	Par. 13, 43
Mind: Planetary Sojourns	Par. 2
Possession	Par. 20
Soul Retrogression: Grudges	Par. 58
Vocational Guidance: Healing	Par. 9, 20, 21, 73-A
Will	Par. 4

TEXT OF READING 1397-1 F 58 (Chiropractor, Naturopath)

This Psychic Reading given by Edgar Cayce at his home on Arctic Crescent, Virginia Beach, Va., this 4th day of July, 1937.

2. In the interpretation of the records as we find here, these as we interpret are that which has been builded in the experience of the entity as an entity, during those periods of activity either in the earth's plane as manifested through the emotional forces or activities, or the sensory force, or in the astrological aspects or sojourns of the entity in the environs about the earth that make for the innate or intuitive influences.
3. As we find from the records, these have been rather well applied.
4. Hence we have the astrological urges and the urges from material sojourns being well balanced through the will, which is used for the activities in the material plane for developments or retardments.
5. These in the experience of the entity then have been rather extremes.

6. Hence we find rather these as a compilation, or a combination of the influences:...
13. But doing good for evil, being gentle when harshness is manifested, makes for that attunement to the influences within the soul as well as in the experience of an entity in material activity, of harmony and peace and quiet.
14. One may not sow riots and reap harmony. One may not sow indiscretions of any nature and expect the mental, the physical or the spiritual to respond as an instrument attuned to only good.
15. But they each in their sphere of activity must be met in same.
16. Hence the experiences of the entity as we find become as these in the astrological aspects of same:
17. One under those influences and forces of Jupiter that makes for the great relationships with masses, but individual in its activity; that is, those activities of the entity in relationships with individuals accelerate - yes, affect groups, communities, states.
18. Thus, as has been given, there is the leaven or the turmoil; that may make for that which may become good in these relationships of the entity and of many others, or just the reverse.
19. In those influences as we find in Mercury and Mars, these are at variance off in their relationships with individuals.
20. Hence madness upon the part of others may oft be quieted by the entity; even possession or obsession in the minds of others may be quieted by the entity.
21. For in the appearances in the earth, as well as in those activities in Mercury and Mars, the entity has become one that may be said to have conquered much in the abilities to quiet others...
56. As to the abilities of the entity in the present, then, and that to which it may attain, and how:
57. It has been indicated that the greater experiences in the earth have been for advancement.
58. Do not let those things that were as grudges, that were as differences, again ever build that which may become as destructive forces.
59. But first know self and in Whom as well as in what ye believe.
60. Then, studying to show thyself approved unto same, never making for that questioning in self or of others as to their purposes - so long as they are constructive.
61. Wipe not thy skirts from those that may be questioned, but from those that are wordly-wise and satisfied with themselves pull aside thy skirts oft.
62. For these are they that make for the stumblingblocks in the experiences of men, and will produce those that have been and are the turmoils of a mental and material world.
63. Keep the faith that has been a part of thy present experience. For the SIMPLE faith confoundeth the wise.
64. These are the things that make for the greater development....

73. (Q) What can I do in my present healing work to produce greater efficiency both from my patients' standpoint and my own?

(A) The natural tendencies and inclinations in the healing are such that, if the entity will use more and more of the magnetic forces of self, closer and closer may the entity come to be of a help to those who seek aid.

More and more the use of those vibratory forces - as is understood - also brings material gain. For again it is not alone from the earth's storehouses but from the universal forces that strength of material natures may materialize in this experience for the entity.

Hence these: More and more of the personal self given. More and more also of the dependence upon etheronic, the electronic influences in those disturbed in body and mind, for the greater material gain.

74. (Q) With which type of the following machines will I be the most successful: Calbro-Magno Wave, Ellis Micro-dynamiter, Straborcam ray - aetheronics?

(A) Now these each have their place in the experiences of types of individual activities. But the aetheronic offers the greater advantage for a universal influence in the experiences of the individual.

This as combined with the magnetic forces of the BODY, you see, will make for the greater experiences in the present sojourn of the entity.

75. (Q) Can I look for improvement in these machines?

(A) In the latter, or in the aetheronic, yes....

REPORTS OF READING 1397-1 F 58

R6. 2/24/47 TIME article:

AETHERONICS

The defendant in Erie, Pa. County Court was charged with black magic (in the modern legal phrase: "taking money under false pretenses" in the practice of "the healing arts").

Yes, it was true, Chiropractor Alva B. Scott admitted with dignity, he had originated (and practiced) a new healing art he chose to call "aetheronics." It cured diseases by remote control. What was more, he had witnesses.

First, Scott explained, he took a drop of the patient's blood and put it in a small black "analyzing" box. From this he determined the patient's "frequency." Then he tuned the "curing" box to the right wavelength, and its healing waves followed the patient wherever he went, like Mary's little lamb.

One dissatisfied Scott patient complained that the little black box was not the right treatment for her; five experts for the state testified that that did not surprise them a bit. But four prominent Erie citizens, also Scott patients, had a different story. One of them, old Rev. John Keehley, said that after three months of Scott's wave treatment, his voice, cracked and failing these 20 years, grew strong enough to fill the Luther Memorial Church.

While a packed, fascinated courtroom waited, the fascinated jury (two men, ten women) returned its verdict: "Not guilty."

INDEX OF READING 1436-3 F 27

[edited]

Archaeology: Personal	Par. 30-A
Arts: Beauty	Par. 29-A
Bible: Books Of: : Deuteronomy 30: 11--14	Par. 28-A
Healing: Economic	Par. 27-A
Ideals: Belief	Par. 28-A
Knowledge: Application	Par. 30-A
Life: Opportunity	Par. 23-A
Psychic Development: Clairvoyance: Auras	Par. 25-A, 30-A
Vibrations: Color	Par. 26-A
Vocational Guidance: Color	Par. 21-A--28-A

BACKGROUND OF READING 1436-3 F 27

B1. See 1436-1 and 1436-2, a Physical and a Life Reading.

TEXT OF READING 1436-3 F 27

This Psychic Reading given by Edgar Cayce at his home on Arctic Crescent, Virginia Beach, Va., this 9th day of September, 1937.

1. GC: You will give a Mental and Spiritual Reading for this entity with particular emphasis upon guidance that will enable her to direct her activities in the present. Consider the information given for this entity in Life Reading of Aug. 30, 1937, [1436-2], especially as relates to her work with colors. Answer questions.
2. EC: Yes, we have the desire of the mental self, [1436]; this we have had before.
3. Now in the information that has been given regarding the Physical, the Mental and the Spiritual self, there has - been outlined - in consideration of that given - the manner of activities as related to the mental and spiritual self.
4. These the entity has only begun to question, and only a portion has become a part of the daily experience....

21. (Q) Shall I concentrate on color as an aid to charm and beautiful effects and seek opportunities for giving short talks on this subject with the object of presenting it on the screen?

(A) This is very well.

22. (Q) Or should I try for radio work as a better medium or for lecture bookings?

(A) This is very well. As has been indicated, the work with those for the screen and for those activities that make for the activities in same are the more far-reaching, the more effective manner.

23. (Q) Please direct me to the sources where my opportunity may be found.

(A) The first OPPORTUNITY, the first source is WITHIN! After there has been the gaining of the control of self, the body-physical, the body-mental, and a normal equal balance, THEN we will see the conditions opened for thee!

24. (Q) What specific studies should I undertake regarding color?

(A) FIRST study SELF! in relationship to the Creative Forces, as has been the direction. Or the study of auras as related to the individual life, the individual expression in others. For this, as has been pointed out, was the greater portion of the physical activity in the material plane for giving out by the entity during the Egyptian period.

Hence this as applied to material things, or as to commercial value within self, becomes the means, the manners, the way through which this may be given out the most.

25. (Q) In the study of auras, just specifically what should be my approach as suggested in the Life Reading?

(A) Find first that as is within self, and then the associates day by day; until there is gained a more complete or better understanding of what these (that is, auras) represent in the individual - THEIR - activities daily!

26. (Q) Would it be wise for me to undertake a study of photography from the technical angle in relation to color?

(A) This would come later. First learn the basic forces or basic principles of same as related to the bodily forces. Then later they become the activities or the associations in photography. For as has been indicated, if the associations are to be with the moving picture or cinema field, this necessarily becomes a basic force or principle for the very activity. But it would also be well to learn the activity of the etheronic and the vibrations of the body, for these are they that produce color, that produce aura, that produce the activities seen AS color.

27. (Q) Will it be helpful and can it be made a source of income if I learn to operate the radionics and aetheronics instruments?

(A) These would be helpful, and naturally may be made to become a source of income. But learn these not from the standpoint of source of income only; for oft one defeats self by gaining that which is to supply one portion of the body and lets the rest of it go hungry.

Such individuals become then failures, and cannot help but become so - unless there is the response or quickening or vibration in relation to self in the use of same for a helpful thing in the experience.

If it has not proven so in thine OWN experience, leave it alone!

28. (Q) Where should I go for a study of color - the pyramids offer one source - should I go more carefully into this or seek elsewhere? Please give me definite information regarding the best sources for my study of color.

(A) Go more carefully FIRST - Do the first things first! Learn that within self, thy OWN relationships to same! Then the color as given from the pyramid studies - but if - What is the source of these? Remember, as has been given to thee as well as to all - KNOW in WHOM ye believe as well as in WHAT ye believe!

Because there have been theories of what color is presented in the preparation of the message left in the pyramid, is the source - or that as given in the varied ways as to the activities - such that ye can believe in WHO has given this? Or does the study of same answer to something within self and the God-force or Creative Force or Life Force in self that it IS true?

Then the study of same is within SELF and in self's relationship and application to same for thy fellow man. THESE be the studies then; not who will bring a message from above, from below or from beyond the sea, for the MESSAGE is within thee!

29. (Q) Is my immediate type of work connected with helping women to be more beautiful, or what?

(A) That in the immediate may be used as a means, as a way, for the greater study of the whole subject.

30. (Q) Where is the hidden information on the aura best found and where did I leave the records of my work in the Temple Beautiful in Egypt?

(A) These are quite different questions!

The best information of the aura may be found in the study of all that may be found upon the subject, in the MANY varied ways and in the many varied pamphlets.

But the application of same is the real KNOWLEDGE of same, see? To study and to know, or to accept what one has said without a practical application of it is to become lopsided, or to become so centered as not to be able to make practical or to make active use of that which is shown thee day by day.

This is the manner to study the aura. All that has been written that may be found! But the KNOWLEDGE of same is PRACTICAL use of same, and that which is practical in the experience of those to whom ye give aid or help!

As to where the records are - in the HALL of records not yet opened!

31. We are through for the present.

INDEX OF READING 1504-1 F 48 [edited]

Appliances: Radio-Active: Poliomyelitis : Radionic	Par. 46--55 Par. Background, 42, 45
Conscience	Par. 9
Incarnations: Rome	Par. 22--27
Jesus: Crucifixion : Grace: Law Of	Par. 7, 9 Par. 6, 8
Karma: Physical: Poliomyelitis	Par. B2, 3--6, 24--26, 41
Meditation: Affirmations : Appliances	Par. 52--55 Par. 52--55
Physiotherapy: Massage: Myrrh: Poliomyelitis : Oils, Olive: : Peanut Oil:	Par. 44 Par. 44 Par. 43
Vocational Guidance: Education	Par. 38--40
Work: E.C.: Quotations & Similes: "Co-Creator With God"	Par. 15

BACKGROUND OF READING 1504-1 F 48

12/6/37 Letter: "...I was so glad to talk with you on the telephone yesterday. As you recommend, I should very much like to have a Life Reading, at your convenience.

"I believe that you need the following information..." [Personal data -]

"Instead of giving you a definite list of questions, may I suggest some of the things I should like to know?"

"In September 1925 I had Polio Encephalitis, and have not walked since. It has taken a steady toll of general health, nerves and vitality. I am interested to know what led up to this particular Karma.

"Also I should like to know whether the things that I am to do will be worked out within the present physical limitations, or whether it is possible to look for a release from them.

"My life is now organized to minimize the inconvenience of the physical handicap, but I feel that I could be less of a burden to my husband, and of more use to him and the children if I were not so completely dependent on my husband for transportation. (It is almost impossible for me to go anywhere in the City without him.)

"We have expended - perforce - a great deal of time, thought, energy and money in trying to overcome the paralysis, so far without result, and I should feel inclined to weigh very carefully further supplies of these commodities that would have to be spent against the probable measure of improvement, and the time involved in its materialization.

"For the last 18 months I have had daily Etheronic treatments. I believe that there is now a better foundation for improvement and a slightly better prognosis, but no visible improvement has as yet resulted.

"I wonder whether my future work is at all tied up with any of the new diagnostic and healing machines built on the RAY principle?

"I feel increasingly that there must be some mental and spiritual block that must be removed before much physical progress can be made..."

TEXT OF READING 1504-1 F 48 (Housewife, Protestant)

This Psychic Reading given by Edgar Cayce, Virginia Beach, Va., this 30th day of December, 1937.

3. Let that be considered as was given by Him, who is Life and the Light and the Way - to His disciples concerning the man born blind. "Who sinned, this man or his parents that he was born blind?" Let the answer as He gave be thy strength, yea thy knowledge in Him, "Neither this man NOR his parents but that the love of the Father might be NOW made manifest among the children of men."

4. In this ye may find that which is the purpose, that which is the hope, that which is the faith necessary to remove the mountain of doubt, to bring the light of His countenance as thy directing influence and force in thy experiences day by day.

5. From the records here, we find that some of these are at variance to what would be called the purely mathematical or astrological reactions; yet there is indicated that because of the astrological aspects there is the affliction in the body.

6. These then are to be met in a manner that is commensurate with those very forces, influences or conditions in thine own experience that brought this weakness, this inclination. As under the law these are met. As under grace and mercy these are met in Him.

7. For as one soweth, so one reaps; else the very Divine would be mocked among the children of men.

8. Hence it is not by works alone but by grace and mercy, and the gift of the Father, that man comes to know His relationships with the things that are, that have been, and that may be in the experience of each soul in its journey through those environs, those phases of experience that bring the more and more awareness of the divine love as may be expressed, manifested in a MATERIAL world - as well as in the mental and the spiritual.

9. For indeed it is given to man to know. Even as His Prayer, "Thy will be done in the earth as it is in heaven" may become the very life blood of every soul if it will but harken to that still small voice within that answers to thy own good conscience as to whether or not ye be manifesting the God-like life; as to whether ye ARE the sons and daughters of God or as to whether ye be making manifest thy own desires, thy own indulgences, thy own self....

21. As to the appearances of the entity in the earth, we find few - yet definite - in their influence in the experience of the entity, and in the abilities that may be the entity's for manifestations in the present sojourn:

22. Before this we find the entity was in the Roman land, during those periods when there were persecutions of those who held to the tenet of the lowly Nazarene.

23. The entity was among those of the royalty, being closely associated with the activities of Nero - and of those that were in authority during the experience - in the persecutions by the beasts with which men fought.

24. And the entity LAUGHED at those who were crippled by such activities; and lo, they return again to thee!

25. How blest then art thou, that there are those close to thee that ye once laughed at; that are patient, that are kind, that are gentle with thee!

26. Then condemn not thyself. Rather know that ye are experiencing, ye are knowing that in thy activity as was first given - that ye may see the love of the Father manifested among the children of men!

27. And if there is held and kept, not an abaseness but an humbleness before Him, before thy Hope, yea before thy Father-God, there may come greater and greater manifestations; that ye may indeed know there IS a living God, and that He is mindful of the children of men!...

37. As to the activities and the abilities in the present:

38. In these and through such channels may the entity give expressions of those tenets and lessons gained; not only in this experience but through the correlating of all those periods in which the activity gave an expression of self in one manner or another may the entity give in its writing, in its counsel to those of the younger generation.

39. For as in those experiences the entity taught, the entity experienced, the entity proclaimed again and again, upon the shoulders of the young rest the cares of life and of material things; whether it be possessions of the material nature or thought as pertaining to the moral, the economic or the spiritual welfare.

40. Hence the training of such for their activities in their varied fields become channels through which the entity may gain the more.

41. And in meeting the disturbances, look not upon those in the present as afflictions; rather as opportunities for self as well as for those about thee.

42. Use the low electrical forces that have been and are being advised and administered to the self.

43. Also, every third day, massage not only the lower limbs but from the 9th dorsal or the middle portion of the body downward, with pure Peanut Oil.

44. And on the opposite days massage the body with an equal combination of Olive Oil and Tincture of Myrrh; this massage gently but surely given - that is, general massage so that the body in all portions, even to the feet, absorbs all that it may.

45. Then WITH the gentle electrification, with the low forms of same, we may bring a NEW LIFE, a NEW energy to the very cells of the body itself.

46. Occasionally, at least three times a week, use the Radio-Active Appliance in conjunction with the other applications. Use for thirty minutes, circulating the attachments about the body in the manner as has been indicated for such; that is:

47. First time: The first attachment would be to the right wrist, the last to the left ankle.

48. Second time: The first attachment would be to the left wrist, the last to the right ankle.

49. Third time: The first attachment would be to the left ankle, the last to the right wrist.

50. Fourth time: The first attachment would be to the right ankle, the last to the left wrist.

51. In that way a circle is made of the entire body, you see. Then begin over again, continuing to alternate in the manner indicated. The first attachment becomes the positive, the last attachment the negative - see?

52. And during such a period - that is, during the thirty minutes the Appliance is used - let thy meditations be in this manner, but thine own words; letting these thoughts gradually grow, GROW:

53. FATHER-MOTHER GOD, HERE AM I - THY HANDMAID! WEAK, UNWORTHY THOUGH I MAY BE, I COME SEEKING DIVINE LIGHT, DIVINE GUIDANCE; BELIEVING THOU HEAREST THE PRAYERS OF THOSE THAT WOULD KNOW THY FACE! LEAD THOU, O LORD, THE WAY!

54. LET MY BODY, MY MIND, BE IN THIS EXPERIENCE A MANIFESTATION OF THE LOVE THOU HAST PROMISED TO THE CHILDREN OF MEN.

55. THEN USE MY ABILITIES, MY PURPOSES, MY DESIRES, IN THE WAY THOU SEEST, O LORD, THESE SHOULD GO.

56. We are through for the present. [See 1504-1, Par. R1.]

REPORTS OF READING 1504-1 F 48

1/6/74 Letter received from [1504]'s daughter containing:

"...You ask me to make any comments relevant to the Cayce reading on my mother. She suffered from poliomyelitis and many other painful and frustrating conditions during her life. Edgar Cayce, according to the reading, was of the opinion that she could have been healed. To the best of my knowledge, she did not follow through with his advice and told me later that he had given her nothing more helpful than that she was paying off a karmic debt. She lived, in spite of cancer, arthritis, diverticulitis, chronic bladder inflammation, etc., etc., to the age of 83, dying quite senile. It is most regrettable, to her family that she did not make the total effort at self-healing which was available to her..."

INDEX OF READING 1553-11 F 71

Appliances: B Battery: Senile Dementia:
Tendencies Par. 3-A, Reports
: Radionic: Par. 3-A--5-A, reports

Doctors: Taylor, William D.: N.D. Par. 1, Reports

Electrotherapy: Short Wave: Senile Dementia:
Tendencies Par. 3-A, 4-A, Reports

NERVOUS SYSTEMS: INCOORDINATION

Possession: Tendencies Par. 3-A

SENILE DEMENTIA

BACKGROUND OF READING 1553-11 F 71

B1. See 1553-10.

TEXT OF READING 1553-11 F 71

This Psychic Reading given by Edgar Cayce at his home on Arctic Crescent, Virginia Beach, Va., this 2nd day of February, 1939, in accordance with request made by the son-in-law, Mr. [1561].

3. (Q) Would the use of the "Nervosad" [Nervosan?] or bipolar electronics machine be beneficial in this case?

(A) If there is sufficient of the electrical forces given as we have indicated, to allay those tendencies for possession at times, we find that the etheronics and electronics will be beneficial.

If not, then these would prove rather irritating.

This can best be determined, as we find in the present, by a pressure in unison (or one with one hand and one with the other) upon the areas about the 4th lumbar axis and the 3rd dorsal plexus. If with gentle pressure there is the inclination for an excitement, or irritation, then there would NOT be the better effects through the etheronics. But IF there is the inclination for this pressure to quiet, and to cause the tendency for better relaxation, then the etheronics would be well.

4. (Q) Radionic examination shows kidney infection and a certain amount of anemia. Would it be advisable to use a radionic treatment wave for this condition?

(A) This again, as we have indicated here, would depend upon whether or not there is sufficient elimination of those tendencies for the possessive forces in the periods of incoordination. If not, such would NOT be efficient or effective.

If there is the quieting by the effect of the electricity, static in form, from the applications as have been indicated and outlined, and there is the neutralizing set through the etheronics, this would be very well.

5. (Q) Forstia, my teacher who comes in on my Radionic instrument on wave length 3.131 says this case can be greatly improved by Radionics. Do you advise this in conjunction with your other specified treatment?

(A) Such, as indicated, would be all in keeping with that as we have just outlined. Make these tests, and then be guided by same.

6. We are through for the present.

REPORTS OF READING 1553-11 F 71

R1. 2/8/39 Dr. W. D. Taylor's letter to EC:

"Thank you. It certainly is a real pleasure to have letters answered promptly and well.

"Your letter indicates that the electrical device for distribution of the gold solution should be continued in conjunction with the 'Nervosan' [Nervosad?] if the tests you suggest are in accord, however, I am not quite clear on this point.

"Can the 'Nervosan' be used in place of the gold solution at this time? The reason for this question is the electrical device used for this medium of distribution is making sores on Mrs. [1553] that might turn into bed sores or ulcers in her condition. Will you give me a definite answer for this question?

"The 'Nervosan' is a bipolar electronics that runs on 1/2 of a milliamp of electricity which is so slight an amperage that the patient does not feel the voltage.

"In some previous cases this has brought excellent results and at the moment I am very hopeful for Mrs. [1553]'s improvement.

"On the Radionics quantimeter it is possible to give Mrs. [1553] the healing rates of white light which are comparable to gold, silver, or any element desired. If this would be useful I will be only too glad to use it.

"Thank you again for the helpful reading which I will follow exactly and I sincerely hope you and your fine work can touch many people who are in dire need of it."

Sincerely yours, W. D. Taylor.

"P.S. The tests which you suggested I applied to the above case, reacted in quieting Mrs. [1553] and causing her to relax and take deep inspirations."

R2. 2/11/39 EC's letter to Dr. Taylor:

"Have yours of the 8th. Thank you. Since the reaction is such as you state there is no doubt that you have the right idea as to the administering of the Gold vibrations as well as the etheronic energy, so would proceed along those lines.

"Thank you for your interest, and sincerely hope a great good may come to this poor soul from the administration of the treatments as you give them.

"Hoping you will let us hear as conditions develop and assuring you of our desire to help,"

Sincerely, Edgar Cayce

RADIONICS/ETHERONICS CIRCULATING FILE

R3. 3/10/39 Dr. Taylor's letter to EC:

"Mr. [1561] informs me he is writing to you today regarding a check reading for Mrs. [1561], and I thought this might be an excellent opportunity to ask a few questions regarding the case.

"Mrs. [1553] appears to have much intestinal stasis and becomes very toxic and languid when the function falls below her normal, what do you recommend as our best solution of this problem?

"Are colonic irrigations indicated here? If so how often should they be given? How do you find Mrs. [1553]'s mind in relation to the body?

"This has been a very interesting case and I feel we are making progress with it, but slowly, at present.

"Wishing you great success and joy in the work, I remain,"
Sincerely yours, W. D. Taylor.

R4. 3/10/39 [1561]'s letter to EC re [1553]:

"Herewith 9 questions re [1553]. Dr. Taylor said he would send his questions direct. Upon receipt of word, [...] & I will strive to be 'in accord'.

"Seemed a slow improvement, physically, possibly a SLIGHT improvement mentally until last few days. We can but 'hope' with faith.

"Won't go into my own 'feelings' pertaining hereto but will chat re same some day!

"Love to you all," [1561]

Questions:

1. Is there improvement in any direction? 2. What is cause of lack of response & languidness these past days? 3. Is the daily enema advisable? 4. Has she had too many laxative pills? 5. Should gold solution be resumed in some form? 6. What may be done to aid kidney condition? 7. Would General Electric Model B Sun Lamp be of benefit to her left leg or back? 8. Are we carrying out all of the instructions correctly? 9. Is it probable that complete mental clarity may be restored?

R5. 3/16/39 See 1553-12.

INDEX OF READING 1997-3 F 60 [edited]

Appliances: Radio-Active: Insomnia	Par. 10-A
Doctors: Greenbaum: M.D.	Par. 4-A
Electrotherapy: Etheronics: Insomnia	Par. 18-A
: Radionics:	Par. 10-A
: White Light:	Par. 10-A
Exercise: Hypertension	Par. 15-A, 16-A
HYPERTENSION	
Insomnia	Par. 10-A
Neuropathy: Hypertension	Par. 10-A
Osteopathy: Hypertension	Par. 7-A
: Toxemia	Par. 4-A
Psychosomatics: Toxemia	Par. 12-A, 17-A
TOXEMIA	

BACKGROUND OF READING 1997-3 F 60

B1. See two previous readings.

TEXT OF READING 1997-3 F 60

This Psychic Reading given by Edgar Cayce at his home on Arctic Crescent, Virginia Beach, Va., this 10th day of January, 1941, in accordance with request made by the daughter - Mrs. [903].

4. (Q) What are the effects from the injections taken in Houston, Tex., and given by Dr. Greenbaum?

(A) We find that in the main these have been beneficial. If advantage is taken of the tensions being released, and the sources of the disturbances aided, there should continue to be beneficial effects to the body.

There being the disturbances in the metabolism, and the stimuli from the injections being the source of that which has relaxed and brought about a better condition in this circulation, - we find that now the osteopathic adjustments and stimulations from the sources - in the glands, and in the centers from which impulses and activities are received - should be still more effective toward creating better equilibrium.

5. (Q) What is the heart condition now?

(A) As indicated, this generally is much improved.

6. (Q) What is the blood pressure?

(A) This is not normal, but is nearer normal - or nearer to reaching a normalcy at periods.

7. (Q) How can the pulse be kept nearer normal?

(A) As we have indicated, there are centers in the cerebrospinal system from which the general nervous system received impulse, by the reflex activity from brain centers and from the sympathetics, through their coordination with the activity of the organs themselves.

Hence this may best be kept nearer normal through the osteopathic adjustments and stimulation; and these are to be STIMULATING treatments, not merely relaxing treatments, to the secondary cardiac plexus, the vagus center - that stimulates the circulation to heart, head AND the areas from which much of the pressure has arisen (the abdominal area). Thus we should aid in keeping a better pulse.

8. (Q) What should be the normal pulse for this body?

(A) About eighty-two to eighty-four (82 to 84).

9. (Q) Why the coughing?

(A) From the brachial center, as just indicated, there is the lack of that circulation to the trachea and bronchi, from the secondary cardiac plexus. This gives rather the inclination, then, for a tickling sensation from the LACK of the flow. Thus the character of treatments suggested, or stimulating treatments, to cause a better flow there, should reduce those tendencies, - in better drainages, and in lessening the pressure on the thrombosed area - or the circulation between heart and liver.

10. (Q) Why the restlessness at night?

(A) The lack of that coordination between the sympathetic and cerebrospinal circulation. And this would be materially aided by the use of the very LOWEST form of electrical vibration, or that which would stimulate the vibrations in the body-forces themselves - as the Radio-Active Appliance, OR the radionics, from the white light, that is usually administered through the naturopath treatments. Such an one could also give the adjustments needed in the cerebrospinal area.

11. (Q) What causes the chest pain?

(A) Reflex from the same condition as indicated in the trachea and bronchi, from lack of impulse or coordination between sympathetic and cerebrospinal systems; and will be materially aided by the stimulating treatments as suggested.

15. (Q) Should there be any caution in the use of staircase?...

(A) This depends upon the ability of the body to keep its normal equilibrium. Of course, the sudden running up steps or suddenly descending tends to make the keeping of the equilibrium much disturbed. Use precautions, but not necessarily refrain from using stairs.

16. (Q) Any exercise; if so, of what nature should it be?

(A) Walking is the best exercise for the body; but not running, not pushing, not pulling or hauling things about.

17. (Q) What will give confidence to the body that she can build up again?

(A) The removal of the fears, - which as we find can best be done by producing the better equilibrium through the system through the cerebrospinal adjustments and stimulations as indicated.

18. (Q) Any further advice at this time?

(A) These we would do, and as we find the very nature of the adjustments, as well as the low electrical treatments, as well as the character of etheronics indicated, will be the better for this body.

Do that. We are through with this Reading.

REPORTS OF READING 1997-3 F 60

R1. 1/25/41 Daughter, Mrs. [903], reported on readings for both parents, [1997] and [1963]:

"Mother says she knows osteopathy is what she needs now and as long as she thinks that, it will help doubly. The Dr. Miller machine is not to be found, so those treatments will have to wait. Thanks so much for your promptness in giving them and know they'll be better for it."

R2. 2/9/42 EC's letter to Mrs. [2072] [under 2072-6, Reports]: "...Had a very good demonstration of this about a year ago. Mr. [257]'s mother-in-law was at his home and they asked for a reading [1997-1] - was given, but when she received it she said Oh this is meant for my sister I haven't any of these symptoms even, but she left the next day for Tex. and on the day of her arrival there, just the description as given in reading was pronounced by the Dr. making an examination in one of the leading hospitals there."

The Turn of the Century Electrotherapy Museum
Electronic Reactions of Abrams
<http://electrotherapymuseum.com>

Frank Jones: Abram's Oscilloclast

Dr. Abrams was called the "Father of Radionics" and was also probably one of the most world renowned quack medicine peddlers.

Abrams professed that all organisms possessed a natural unique vibration and any disease could both be diagnosed and cured by those vibrations.

He made claims he could diagnose a disease by a single drop of blood and marketed a machine in the early 1920's called an Oscilloclast, that he claimed would cure a myriad of diseases, including cancer. This machine was never for sale but always leased to practitioners for a fairly healthy sum of money.

The Oscilloclast consisted of a very distinctive electro-mechanical interrupter commonly referred to as a tic-toc.

This interrupter consisted of 2 double wound electromagnets and a pendulum mechanism that delivered approximately 200 interruptions a minute. The interrupter has a different commutator that both ran the device as well as supplied a second set of points that has a longer connect time and then a rapid break.



RADIONICS/ETHERONICS CIRCULATING FILE

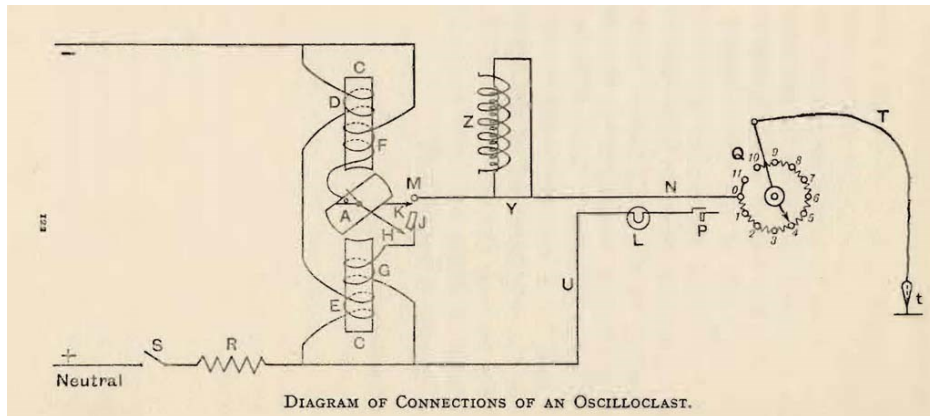
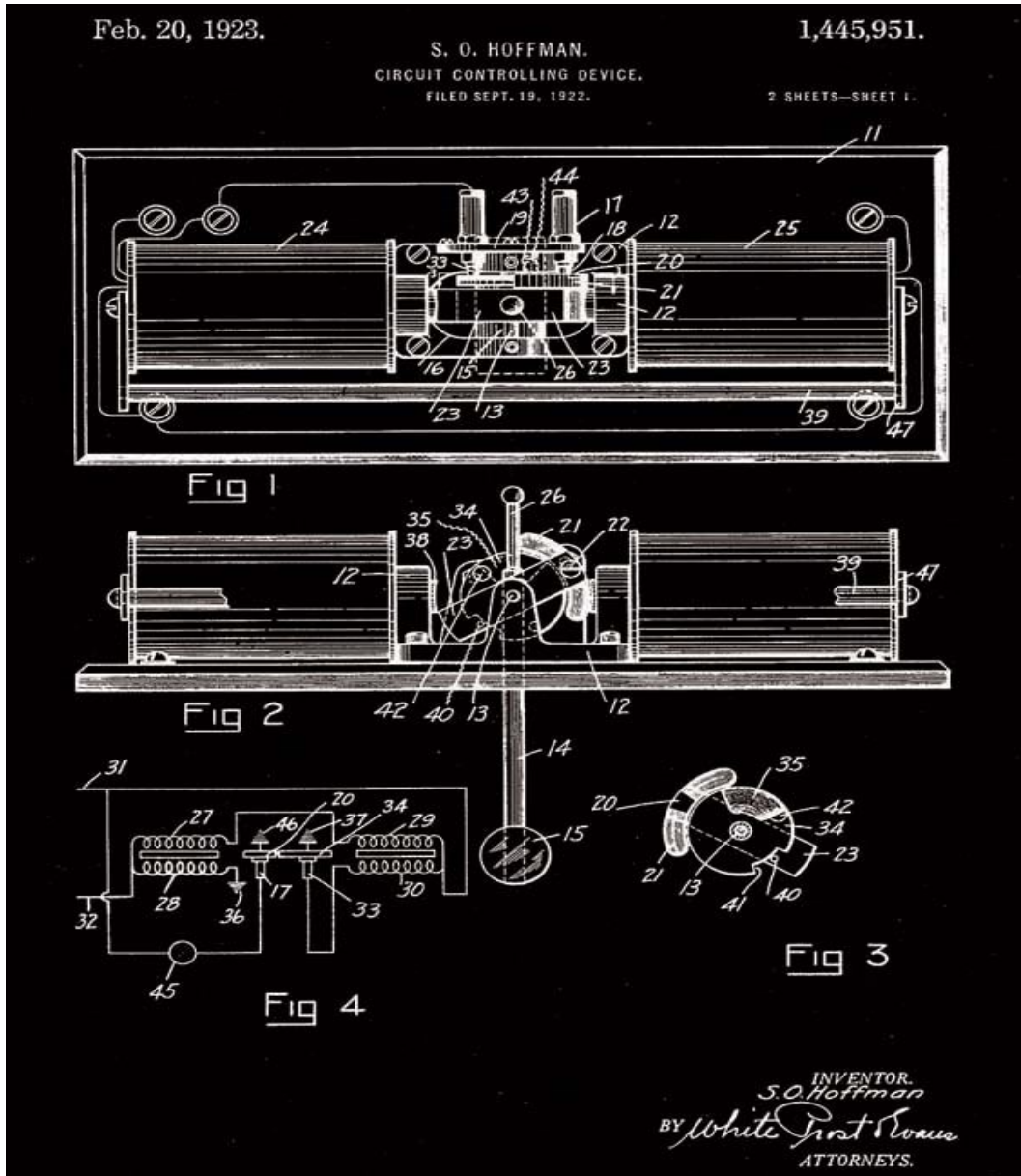

RADIONICS/ETHERONICS CIRCULATING FILE

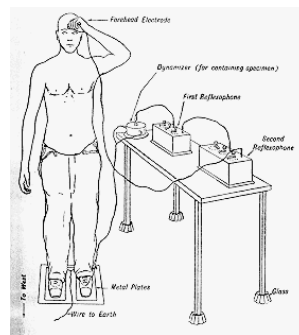
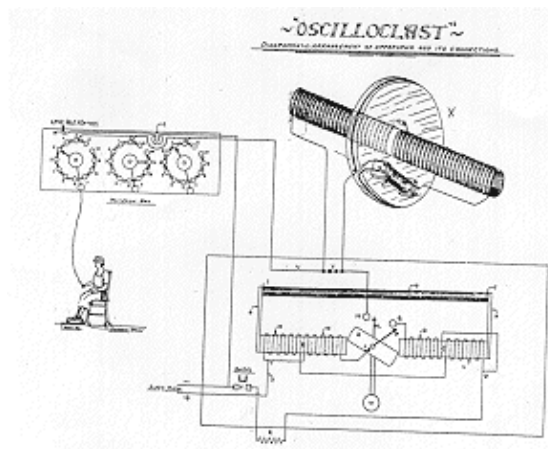
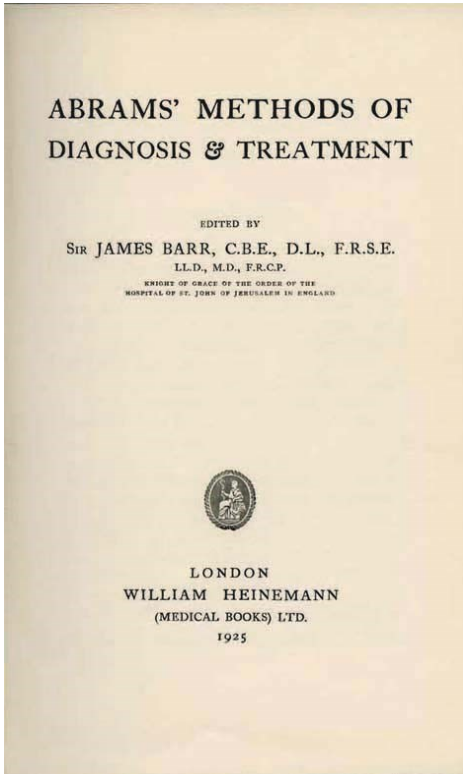

Also see the Internet for other websites: <http://www.royalrife.com/radionics.html>
and <http://www.americanartifacts.com/smma/abrams/abrams.htm>

Edgar Cayce Readings copyright 1971, 1993-2013 by the Edgar Cayce Foundation

INDEX OF READING 3875-1 M 3

Appliances: Abrams Machine: Children: Abnormal	Par. 8, 9, Reports
: Oscilloclast	Reports
: Radio-Active	Reports
Blood	Par. R2
Brain: Plethora	Par. 2, 4
CHILDREN: ABNORMAL	
Doctors: Abrams, Albert: M.D.	Reports
Names: People Mentioned: Doyle, Arthur Conan	Par. R2
NERVOUS SYSTEMS: INCOORDINATION	
Vibrations	Reports
Work: E.C.: Stenographer	Background

BACKGROUND OF READING 3875-1 M 3

B1. This was GD's first reading she took down as EC's steno.

TEXT OF READING 3875-1 M 3

This psychic reading given by Edgar Cayce, in Selma, Alabama, this 30th day of August, 1923, via his aunt.

1. EC: Now we find that throughout the system there are those conditions that are abnormal. These may be corrected. They have to do with the nerve system, and the effect that is produced in the functioning organs. Now these are the conditions as we find them in this body, [3875] Jr., we are speaking of.
2. First, in the blood supply in the body there are times when apparently there is too much blood in its action towards the brain, or central forces, as is shown in the carotid artery, for it gives the plethoric effect to the brain proper at times, yet the condition is of the nerve action rather than the blood or functional conditions of the heart itself, see? And by the muscular forces being contracted, or by co-ordination between the centers or between the sympathetic or cerebro-spinal system becoming properly co-ordinated, we would overcome this condition.
3. In the nerve system we find centers as is shown from the circulation as produced through the effect of the perineurial gland and its junction with that of the pneumogastric center with the secondary cardiac, this being relaxed by this produces overtaxed forces to the body. The sympathetic system over-active, that is in the nerve forces we are speaking of.

4. In the cerebro-spinal blood supply that comes from the centers, through the perineurial and secondary cardiac, gives the condition to the stomach through the pneumogastric center in the heart action and lung forces, as is expressed at times in this system. The functioning organs themselves we find as in these conditions. The brain force, except as is shown through the over activity of blood force, very good.
5. Throat, larynx, thorax, the condition of the throat from excess of secretion through overflow of circulation. Lungs very good for the condition in the centers at seventh dorsal. The heart forces as we have given. That of digestive tract the over activity of the pneumogastric centers is affected sympathetically by the conditions as produced at the [words missing] when the action of the perineurial gland with [words missing] forces become entangled in the blood flow valve.
6. In the liver the action very good, but forced at times to function.
7. To give relief to the body we would produce that vibration in the body that would give the correct incentive for the equalization of circulation and to give the nerve centers the correct vibration to strengthen the centers sufficiently.
8. To overcome these conditions, use that of the Abrams cycloclast [?] [oscilloclast?]* with 37 ohms to the body, the plates being placed at the umbilicus center and the opposite placed on the wrist and at the seventh dorsal.
9. There should be at least forty hours of vibration given this body. Not all at once, but every third day give the vibration.
10. Do that.

[GD's note: My friend, the aunt of [3875], told me later that the parents did not follow the treatment. All I know is that she spoke of the child as afflicted since birth; he was not a baby at the time the reading was given - but was somewhere under twelve; at least that is my recollection.]

* [See 10/79 Beacon article under 440-16, page 74, mentioning Dr. Albert Abrams' machine, the oscilloclast.]

REPORTS OF READING 3875-1 M 3

R1. 1/13/70 San Francisco Chronicle Article:
MILLIE'S COLUMN

THE EMINENT MEDIC - TURNED - QUACK

By Millie Robbins

IT WAS just 46 years ago today that Dr. Albert Abrams died in San Francisco, where he had been born 61 years before. Obituaries in the local press were lengthy as were those in other major cities including New York, where the Times ran a story that measured well over a full column of fine print.

Perhaps no more puzzling and controversial character ever was spawned in this city.

Dr. Abrams was pronounced a quack and denounced by his colleagues. However, unlike other who have been branded medical charlatans, he had been well educated, began his career auspiciously, was once highly respected.

In 1882 he received his M.D. degree from the University of Heidelberg, where he was considered a brilliant student, and later studied in London, Paris, Berlin and Vienna. Returning to San Francisco, he became a professor of pathology and director of the clinic at the Cooper Medical College, subsequently part of Stanford University Medical School.

For several years he was a consulting physician at French and Mt. Zion Hospitals. He has been president of the San Francisco Medico-Chirurgical (archaic for "surgical") Society, vice president of the State Medical Society, and a fellow of the Royal Microscopical Society of London. His name appeared in "Who's Who."

Money presumably was no factor in the astounding change that was to come. Dr. Abrams prospered financially and furthermore inherited sizable fortunes upon the deaths of each of his two wealthy wives. But something happened...

In 1912 the medical profession was thrown into an uproar when he announced that by manipulation of certain nerve centers in the body he could relieve ailment hitherto held only curable by the knife.

He developed an electronic reaction theory of diagnosis and once demonstrated how from his office here he could determine the specific areas of illness of a woman patient in Los Angeles. This publicized performance rated a "success," was done by projecting "radio-activity" over a telephone wire from her to an electrode placed on the spine of a healthy man in this city.

In 1913 he caused another furor by contending that through the play of different colored lights on a prospective mother it would be possible to control the sex of her unborn child.

Another of his claims related to the detectability of romantic feelings.

"The human organism is just a great machine which constantly throws off vibrations," he told a reporter.

"Love, hate and all other emotions have characteristic vibrations. It will be a simple matter to determine whether one person loves another by isolating the love vibrations and seeing in which direction they go."

Meanwhile, orthodox physicians seethed and shuddered. Then after a strong attack in the American Medical Association's Journal, he resigned from that group.

Dr. Abrams regarded himself as another in the long list of scientific pioneers damned in their day only to be later glorified.

We'll conclude his saga tomorrow. [See Par. R2 below.]

R2. 1/14/70 San Francisco Chronicle article:

LEGACY OF A QUACK

By Millie Robbins

Dr. Albert Abrams, originator of a so-called electronic system of diagnosis and cure whom you met here yesterday, left one of the longest wills ever filed in San Francisco.

A number of relatives and a couple of philanthropic institutions were named as legatees, but a goodly portion of his fortune was earmarked for a medical

college and hospital ("where the poor would be treated without charge"), which at the time of his death on January 13, 1924, already was under construction.

This was a ten-story building at Sutter and Hyde Streets. It was to be known as the Blanche (Bachman Schwabacker) and Jeanne (Rath) Abrams College of Electronic Medicine in memory of his two deceased wives. Both had left him considerable money.

But the project soon had to be abandoned, and the building subsequently was transformed into a hotel.

Although his estate was estimated by those acquainted with the doctor's affairs to have been in the neighborhood of \$2.5 million, this proved to be far from correct. It amounted to around \$771,000 including, presumably, his handsome home in Sea Cliff, complete with fine pipe organ.

For one thing, when the assets were collected and appraised, it was found that many patents, copyrights, formulas and the like were of dubious value. The inventory numbered such items as a patent for a pants presser and stock in a scheme to harness power from ocean waves.

The rental from medical devices that had brought in a substantial income during his lifetime, decreased almost to nothing after his death. Disciples had paid him large fees for courses of instruction in either his clinic on Sacramento Street or in one of a dozen other schools that had been founded around the Nation.

Each pupil had to lease an "oscilloclast", paying \$200 or more down and \$5 a month rent. (The cost of manufacturing these was believed to have been about \$30.) Neither that instrument nor any of the other pieces of paraphernalia (one purporting to induce an electric jag!) could be bought outright. Moreover, the oscilloclast lessee had to sign an agreement never to open the sealed box.

Incidentally, while so many of the doctor's inventions appear to have been completely absurd, a few approached the legitimate mark. He claimed, for instance, to be able not only to diagnose diseases but nationality by testing the vibrations of blood. In fact, in 1922 Judge Thomas Graham admitted as evidence in an alimony suit an electronic blood analysis ostensibly showing that the defendant was the father of the plaintiff's child.

In 1923 he demonstrated a new "truth detector" for renowned Chief August Vollmer of the Berkeley Police Department. It was so attuned, he said, that it reacted to life and death, could distinguish falsehood from fact, locate missing persons and determine whether a signature was genuine or a forgery.

When Sir Arthur Conan Doyle visited here around the same time, he gave Dr. Abrams a photograph to test. It showed a living man supposedly surrounded by spirits. The contraption gave a reaction indicating that the central figure was a living being and all of the others were negative.

For diverse reasons his estate was involved in litigation for five years, and by the time a settlement was reached it had dwindled to around \$100,000.

Exponents of Dr. Abrams' electronic system still were carrying on to some extent here as recently as 1953 when the U.S. District court secured a permanent injunction to halt the distribution of the medical devices.

INDEX OF READING 5138-1 F 51

Appliances: Abrams Machine	Par. Bkgd, 4, 10-A
: Radionic	Par. Bkgd, 4, 10-A
: Wet Cell: Pelvic Disorders	Par. 6

CHOLECYSTITIS

Diet: Vitamins: Pelvic Disorders	Par. 10-A
----------------------------------	-----------

Electrotherapy: Short Wave: Iconoclast: Pelvic Disorders	Par. 4, 6, 8
---	--------------

Head Noises	Par. Bkgd, 2
-------------	--------------

Healing: Consistency & Persistency	Par. 5
------------------------------------	--------

PELLAGRA

PELVIC DISORDERS

BACKGROUND OF READING 5138-1 F 51

Born in Austria 3/27/93; one child; occupation: "None".

8/16/43 Letter: "About 1 1/2 years ago, the doctor who was treating me, informed me he had done all he could for me and advised me to have my gall bladder out, and part of the large intestine, etc. At that time, the intestine raised up into a hard bunch many times a day. It all seemed very hopeless. I was taking about 9 different shots about twice a week. I then and there quit the shots and decided only God could help me. In a few days a friend asked me to allow her to make an appointment for me to go to Dr. Drown, [See 5138-1, Par. R4] who improved the Abrams instrument, a radio which tunes into the body. She has done wonders for me. She has treated me for an abscessed condition of the gall bladder this condition spread to kidney, ovary and throat, one after the other, also certain glands did not function. My salt balance was completely off balance, my thyroid bothered me a lot. Have pellagra which even registers in brain. At present, am being treated for an abscess at the base of my brain, also one in right side, pellagra, etc. The abscess in head has been there, I believe, since April. I have a roaring in my head, my ears and nose give me a lot of trouble. My biggest trouble is fatigue, which acts like a drug. My present treatments are being broadcast to me. My deep desire is to find out what is causing the manufacture of all this poison and eliminate it..."

8/21/43 EC's letter: "...I know something of the treatments with the Abrams method. If whoever is treating you has gotten a correct analysis, this should help..."

8/28/43 Letter: "Your letter of August 21 on hand. Happy to hear you know of and approve the treatments I am now receiving. They seem to be keeping me alive, and I will certainly continue them. I want to be worthy of all that has been done for me, and feel thru your help, Dr. Drown will be informed of the right rate, in the right place to destroy the seat of the infection in my body..."

4/4/44 Questions submitted in addition to those at end of 5138-1: "(1) Pain, bunching up and gas in side? (2) Roaring in head? (3) Itching in ears and pain? (4) Pain and numbness in hands and arms at night? (5) What is wrong with left ankle? (6) Should I continue with patches in nose?"

TEXT OF READING 5138-1 F 51 (Religious Preference: "Metaphysical")

This Psychic Reading given by Edgar Cayce at the office of the Association, Arctic Crescent, Virginia Beach, Va., this 19th day of May, 1944,.

2. EC: Yes. Yes, we find a great deal of disturbance here. The activities through the alimentary canal, the disturbance that has long existed in the gall duct area, which has been the source of cause of the lack of proper digestion through the alimentary canal, are only a portion of the great distress. For the pressures through the organs of the pelvis, upon the nerves of the central nervous system, give great distress to all the organs of the sensory system, especially the ears, at times the eyes, at times causing the inability of taste, at times having the effect upon the vocal box.

3. All of these suffer, as do the organs of the central nervous system.

4. As we find, the applications that are made in the present are very good, these are in the right direction. But we would have those vibrations as will analyze the disturbance in the body, through such a one with the iconoclast machine, as Dr. Mary Miller. These may be set so that, even from ten to twelve treatments, the absent treatments radionically given may be administered to the body.

5. These as we find offer the greater possibility and will be helpful. As to the sustaining of help, it will depend upon the consistency of the body in following the directions.

6. When the body has taken these, the iconoclast treatments, for a period of some three weeks, we would add to same the vibrations as may be obtained through the Wet Cell Appliance carrying Chloride of Gold to the body itself. To be sure, this might be given through the machine, but not as effectively for direct aid as it would be through the Wet Cell Appliance made in regular order. The applications of the Chloride of Gold would be with the smaller plate to the 9th dorsal; the larger plate (the wire of which passes through the Gold Solution) attach to the umbilical and lacteal duct plexus, which, on this body would be two fingers from the navel center to the right and four fingers up. Attach for thirty minutes each day. Use at least 3 oz. (of 1 grain to 1 oz. as the strength) of the Gold Chloride, Sodium Gold Chloride for the body.

7. Do that.

8. This we would take for thirty days, and then we would return for more treatments radionically. These should bring help for this body.

9. Ready for questions.
10. (Q) Should I discontinue the treatments and vitamins now being taken?
(A) As has been indicated. Don't discontinue the vitamins. But the machine, as has been indicated, is not set properly. Do have the change as may be obtained through the administrations of Dr. Miller, Los Angeles, Calif.
11. We are through with this reading.

REPORTS OF READING 5138-1 F 51

R1. 6/5/44 Letter: "Readings for daughter [5137] and self, received. Thank you for giving me new hope. We will follow instructions to the letter. Have contacted Dr. Miller as you instructed. She is treating me. I like her very much... Am sending for Appliance today. Have no extra instructions for him. Please send him a set as soon as possible. I shall be ready for it in about 3 weeks. Regarding check Physical, please set this reading ahead to 9/31st..."

R2. 9/4/44 Letter: "I am so happy to report a great improvement in my physical and mental condition. I thank you for everything; you have given me a new lease on life. May your life be a long and peaceful one. Reading 'There Is A River' gave me courage and faith to see things thru. I developed a severe case of neuritis in my arms the first month's treatment. The pain was almost unbearable, especially at night. The improvement in arms the last month has been wonderful. Thank God. The severe headaches of the past have grown much less severe. I still have the roaring in head. Pains in head, ears and throat, but much less painful. Dr. Miller is tops. My left ankle is very painful - a burning, tickling pain that affects part of calf. I've had it for a year now. I hardly know what to do with my foot. Lately it has begun to swell. I do hope you can help me clear it up. I've lost track of the many things that have cleared up since your first reading. Here are my questions. I shall list them, preferred ones first in case I over-stepped the right in asking too many. The cause and cure for the following: (1) What is the matter with my left foot and ankle? (2) How long should I take Wet Cell treatments? (3) How can I regulate and normalize bowel? (4) How can I improve my vision - my eyes have grown noticeably dim the past year. (5) Is my diet all right?..."

R3. 5/17/45 Letter: "Please send me your booklet on Physical Readings; also any sinus remedy you know is helpful."

R4. 10/6/51 Los Angeles Evening Herald & Express article (Saturday):

Controversy Over Weird Healing Gadget

Mrs. Allen Had Faith In Device

Federal Court Finds No Remote Control Cure In Medicine

Mrs. Eleanor B. Allen, president of the Los Angeles Board of Education, may believe in magic, but the Federal Court doesn't. Neither does the American Medical Association, nor the Los Angeles City Health Department.

Accordingly, Dr. Ruth B. Drown, Hollywood chiropractor who invented the gadget Mrs. Allen claims cured her of pneumonia by remote control, will be sentenced Monday in Federal Court.

And the City Health Department has prepared a broadside implying that Mrs. Allen is a very credulous woman to head the city's educational system.

CURED PNEUMONIA

It all began when Mrs. Allen on a visit to Atlantic City thought she was getting pneumonia. But radiation from Drown's electronic device, set up in Los Angeles, cured her right up, she declared.

Mrs. Allen said last week that the American Medical Association was "closed minded" because it ruled that no such thing could happen.

Now another medical authority stamps on the mysterious little black box with which Dr. Drown practiced "radiotherapy."

Dr. L. S. Goerke, director of the Bureau of Medical Services for the City Health Department, will publish a broadside in next week's Health Department Bulletin deploring such "absurd claims" for modern medicinal machines.

HITS CONFUSION

"Confusion caused in the public mind by endorsement of such gadgets by the president of the Board of Education should be clarified and corrected by factual information," Dr. Goerke declared. "In 1951, in the world's most literate country, we have magic for the cure of disease."

The publicity Dr. Drown got with her little black box rebounded to her discomfiture. A federal jury held that the little black box and the wires it contained neither diagnose nor cure all human ills - or any of them.

The jury got her for "mislabeling," under the Food and Drug Act.

Dr. Drown today denied that she claims her machine, like the fabled product of Lydia E. Pinkham, will "cure all human ills."

"We don't claim it will cure anything," she said. "The patient heals himself. We only help nature to do her work faster."

In 1946 Dr. Drown received a Certificate of Merit from the New York Museum of Science and Industry for her "miracle machine."

CLAIMS REMOTE CONTROL

"The museum was part of the Rockefeller Foundation at that time," she explained. "I understand that since all this has happened that it is no longer in the foundation."

Dr. Drown said she does claim the electronic device diagnoses by remote control.

"We take the only soft tissue pictures of the human body through the air" she said, "and that proves our claims. We have made these pictures from here to England and from England here, before groups of doctors."

She intimated that organized medicine is trying to put her out of business and smash the little black box.

"Anything that is valueless doesn't have all that money spent to get rid of it," she insisted.

R5. 10/13/51 Los Angeles Times article (Saturday):

SCHOOL BOARD HEAD BACKED "RAY" CLAIM

Mrs. Allen's Testimony on Behalf of Inventor Discloses Belief in Remote Control Doctoring

Mrs. Eleanor B. Allen, president of the Los Angeles City Board of Education, is a firm and long-time believer in a disproved "radio therapy" machine whose manufacturer faces a Federal sentence for falsely claiming it can treat cancer by remote control across the continent.

Mrs. Allen's testimony in U.S. Court on behalf of the machine and its originator, Dr. Ruth B. Drown, was disclosed yesterday as sentencing of the defendant was continued until Oct. 22.

A voluntary, unsubpoenaed witness for Dr. Ruth B. Drown, Mrs. Allen told a jury in U.S. Judge Harry C. Westover's court recently of her faith in the gadget that Dr. Drown claimed could diagnose and treat literally thousands of ailments by tuning in on a drop of blood and broadcasting healing rays.

OPINION OF PANEL

She and her husband, Dr. Walter W. Allen, a Drown student, insisted the machine is a scientific marvel, although a scientific panel at the University of Chicago last January branded it "worthless."

Under cross-examination by Asst. U.S. Atty. Tobias G. Klinger, Mrs. Allen said the Hollywood chiropractor's device once cured her of pneumonia when she was in Atlantic City, N.J., and the machine was in Los Angeles.

Mrs. Allen said she had known Dr. Drown for 18 or 19 years and had given her a sample of her blood, which Dr. Drown kept on file. All that was needed to cure her of any ailment, the board president testified, was to have the machine broadcast treatments to her wherever she was.

INVESTIGATION BY FCC

An investigation of the machine by engineers of the Federal Communications Commission in 1947, according to Klinger, brought out how one male patient was subjected to "rays" from two plates that were found to be connected to the antenna and loudspeaker of a radio dialed to a local station.

Dr. Drown only requires a single drop of blood, Klinger said, because she contends the crystal formation of the blood remains the same always, like the crystals in radios. These crystals are supposed to activate the machine with the correct healing rays or, tuned in differently, to accomplish "absent diagnosis."

Klinger emphasized the trial and conviction of Dr. Drown was not intended as a slur on the chiropractic profession.

BOARD'S CONCLUSION

Dr. Willard W. Percy, secretary of the State Board of Chiropractic Examiners, testified as a prosecution witness that in 1947 the board branded Dr. Drown's invention as "without therapeutic value."

Other expert witnesses described the machine as simply an "inefficient battery tester" which wiggles the needles of its dials better when used with a glass of water instead of a human.

The needles are activated, the experts testified, because human bodies - as well as an assortment of inorganic objects - act as natural conductors for the passage of current between two pieces of dissimilar metals.

The University of Chicago conducted its tests with Dr. Drown's consent and at the request of a Chicago society leader, formerly one of Dr. Drown's patients. The mother of Actor Tyrone Power was present at the first sessions at the university, being at that time an ardent follower of Dr. Drown.

Dr. Drown at that time described her machine as "an apparatus which I claim utilizes the crystals in the drop of blood held together by a blotter which is in resonance with the energy that is tuned in from the body or other substance."

Her claims, the investigative scientific panel concluded then, "appear to be totally unworthy of serious consideration by anyone, least of all by the university."

HYPOTHETICAL QUESTION

Klinger, the transcript of Dr. Drown's trial disclosed, asked Mrs. Allen a hypothetical question which in substance was this:

"Assume you were riding in an automobile in Moscow and Dr. Drown and her device were in Hollywood. You had an accident and received a broken leg, a fractured skull and were hemorrhaging. By telephone, Dr. Drown was informed you had been in an accident - nothing more.

"Using your blood sample on file, Dr. Drown would tune in the machine, which would diagnose your condition. Then she would tune in the treatment device. Is it, then, your contention that this would cure your broken leg and fractured skull and stop your hemorrhage."

"Yes, yes," Mrs. Allen testified. "The way you state it, Mr. Klinger, sounds like black magic, but it isn't. It's science."

MACHINES IN HOME

Asked if she would seek a surgeon instead of the machine if she required surgery, Mrs. Allen said that use of the machine would preclude any need for surgery. The board president said she has two of Dr. Drown's machines in her home, but is not versed in their operation.

Asked why, if the machine is so effective, her husband has been ill for five years, Mrs. Allen replied:

"That machine has kept him alive."

The board president also testified that use of the "broadcast treatment" cured a rash that appeared on the hands of her son Tommy. Dr. Drown called the healing power of her invention "the invisible life force."

"ATLAS" QUOTED

Dr. Allen, according to Klinger, is a former chiropractor who studied Dr. Drown's "radio therapy" methods and often collaborated with Dr. Drown in the treatment of Mrs. Allen.

During the trial attention was called to the "Drown Atlas," a sort of instruction book for doctors employing the machine. It is prefaced with a warning, a portion of which reads:

"Let us say here, for the benefit of those who do not know, that any patient who is weak and depleted should never take shower baths and stand in the water over the drain, because the patient's magnetism is washed down with the water through the drain, leaving him depleted.

DOWN THE DRAIN

"Also a week patient after having a tub bath should leave the tub and have someone else drain the water and clean the tub... Too many people sit in the tub and drain the water before finishing the bath and their own magnetism is drained through the drain pipes to the ground, leaving the patient with much less reserve."

Asked his opinion of this advice, Dr. Allen said he always took tub baths when possible.

"I usually let the cold water run into the tub before I get out because that is your source of pure energy coming right from the springs and the source," he told the jury.

"I get out of the tub before letting the water out and I clean the tub with a long-handled brush. I don't get down and rub it with a rag."

R6. 7/3/72 Virginia Beach Ledger-Star (Monday) article:

HOSPITAL HEAT MACHINES ARE CONFISCATED BY FDA

NORFOLK - Federal Food and Drug Administration officials have seized two heat treatment machines owned by Norfolk General Hospital in the first step of a planned nationwide confiscation.

The machines, manufactured by the Diapulse Corp. of America, were claimed to be useful in treating some 300 diseases, and wounds, including arthritis, bursitis, fractures and infections - a claim labeled as "nothing less than sheer quackery" by a federal judge.

Robert Case, an agent for the food and drug administration in Baltimore, said today some 4,000 of the machines are in use by hospitals, clinics, chiropractors and other practitioners.

Norfolk General was singled out as the first target because federal court action "is faster" here than in Washington or Maryland.

The FDA had picked up samples of the machine in 1969, Case said, but the firm has been fighting action in the courts since then. An injunction against manufacture has now been obtained, he said.

The devices have been sold since the late 1950s at prices ranging from \$2400 to \$4000 each.

Although the machine itself is not harmful, Case said, harmful effects could result if someone suffering from a serious disease used it in lieu of appropriate treatment.

[7/5/72 GD's note: I added above clipping to 5138-1 Reports because the preceding pages contain clipping of previous court fights over a mysterious 'magic cure' machine used by chiropractors.

Case 5138-1 on 5/19/44 called for the use of a short wave iconoclast machine, followed in 3 weeks with the Wet Cell Appliance carrying gold. The patient [female, 51 yrs. old] had cholecystitis, pellagra and pelvic disorders.]